



Propelling your fleet further

Today's bespoke driveline solutions
for tomorrow's vessels

Beattys

DRIVELINE
MARINE

It's the thinking before production that makes our drivelines different.

**YOUR PROBLEM.
OUR PASSION.**

We live and breathe drivelines. Every project is a different proposition – and an opportunity for us to craft the best solution.

At Beattys, we understand that the marine environment and demands of the industry present the ultimate challenge for product quality and durability. Our design expertise has been proven time and time again; working with some of the leading naval architects and renowned boat builders worldwide.

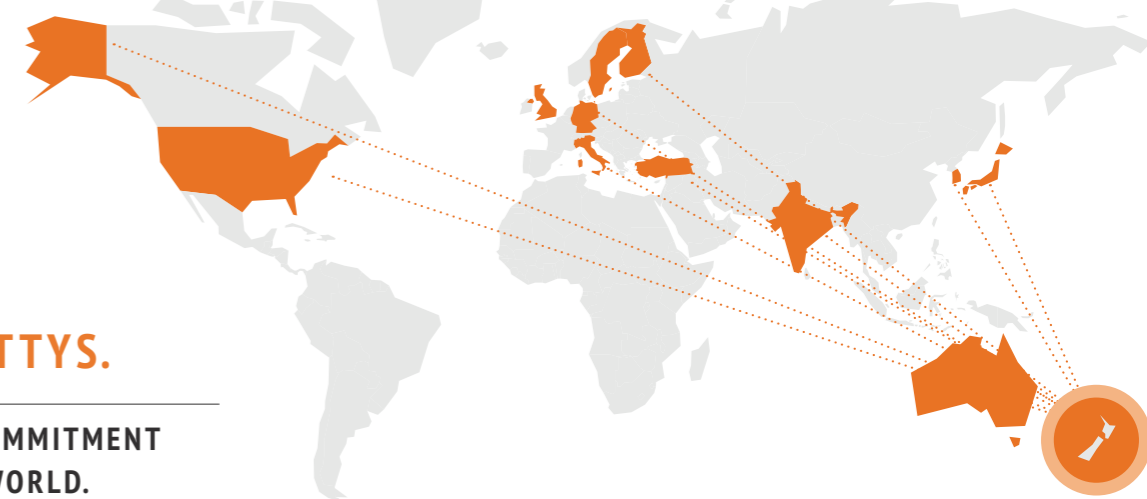

WE ARE BEATTYS.

FAMILY-OWNED COMMITMENT FROM NZ TO THE WORLD.

Family-owned businesses have something special. A core value that larger corporations cannot duplicate. When you have three generations of a family involved in a business, there's a genuine desire to look out for those people who work in, for and with the business. And there's a will for the business and our customers to collectively succeed. Since 1963 three generations of our family have given their best to ensure that Beattys Drivelines reputation as a quality manufacturer, supplier and employer is entrenched with those we value most - our people, our customers and our suppliers.



100% FAMILY OWNED



VIP CUSTOMER SUPPORT



MANUFACTURED IN NZ



QUALITY COMPONENTRY

LEADING-EDGE DESIGN INNOVATION

The intelligent design of a driveline is very critical to ensure ongoing reliability. It is important that the power source, speed and universal joint angle are ascertained prior to specifying a shaft to suit any situation. We offer a full consultation and design service so your custom requirements can be met with products that deliver optimal performance.

STATE-OF-THE-ART MANUFACTURING



Turret is our legacy. With over sixty years of experience, we are one of Australasia's most trusted manufacturers and suppliers for all driveline needs. Turret drivelines and componentry are designed and hand built to extremely high standards here in our state-of-the-art facility, and backed by our dedicated and accessible team.

Our attention to your detail

1 ASSESS

Beattys will scope the project, identifying any critical parameters and challenges that we need to overcome to ensure we deliver a premium product.

2 DESIGN

Our team of technical engineers will then design a custom solution using state-of-the-art CAD and programming systems to ensure that we will meet all the client's needs.

3 MANUFACTURE

Throughout our driveline manufacturing process, you can be guaranteed of the highest level of engineering excellence and commitment to quality.

4 BALANCE

All drivelines are dynamically balanced in one of our four, multi-plane balancing machines. We spot-weld any weights to reduce stress on the driveshaft tube. Beattys also offers balancing services for propeller shafts and fans.

5 REVIEW

Once a driveline has been dynamically balanced and painted, it goes through a series of rigorous inspections and quality control measures to ensure the products we deliver will fit our commitment to premium quality.

Global supply capabilities

PROJECT CAPACITY

Whether your project is a 65hp pleasure project vessel, quad engine 300 passenger electric ferry or 2500hp military patrol vessel, Beattys Driveline has the in-house capabilities to design and manufacture marine drivelines to suit all duty applications from pleasure to heavy commercial.

RAW MATERIAL

More than 30,000 driveshaft components stocked locally in New Zealand make Beattys Driveline one of Australasia's leading driveline specialists.

EXPORT

Supporting our valued global client base, Beattys Driveline despatches componentry and complete drivelines worldwide via our international freight partners.

DRIVELINE RATINGS

200Nm - 750,000Nm torque capacity ratings, and connection flanges from DIN 58mm to DIN 480mm.

Marine Driveshafts

Powering the marine industry with optimal performance.

KEY STRENGTHS & BENEFITS:

The marine environment and demands of this industry provide the ultimate challenge for product quality and durability along with the need for proven design expertise. Beattys has risen to this challenge and for many years has enjoyed working alongside Australasia's leading naval architects; assisting them with marine driveline design and is now the preferred supplier for renowned boat builders throughout the region.

Beattys Driveline has made significant investment into specialised equipment and also technical know-how training to ensure our team is at the forefront of the marine industry's requirements, delivering excellence and premium driveline solutions.

All componentry, processes and workmanship are of the highest industry standards and trusted globally by mariners operating both commercial and pleasure vessels.

Premium driveshaft solutions.

European involute-style splines that are larger in diameter with finer tolerances and less clearance result in quieter operation, increased capacity and longer service life.

Rilsan® coated splines reduce axial load and provide electrical isolation between shaft ends.

Sliding spline assemblies have heavy duty housings and an integral seal system that protects from contamination and wear.

Marine grade 2 pack industrial coating preventing corrosion in harsher environments.

Automated welding process allowing deeper penetration and precise control while maintaining maximum consistency.

Internal thrust washers allowing the universal joints to run cooler and minimise noise and vibrations from clearance.



High grade tubing with internal tube damper increasing the resistance to high shock loadings.

All driveshafts are balanced to ISO 1940 Grade 6.3 standard and balance weights are spot-welded to prevent fracturing and stress on the driveshaft tube.

Option of completely sealed universal joints to keep maintenance to a minimum and ensuring engine room cleanliness. Greaseable options also available for higher angle applications.

Custom made flanges to suit any gearbox, engine or prop shaft and remove need for additional adapter flanges.

CV Shafts



OVERVIEW

Turret CV joints and shafts make it possible to have unequal angles on the two ends. This, coupled with a maintenance-free and a low axial force ball design results in long lasting, high performing solutions.

SPECIFICATIONS

- Short coupled options for minimal length requirements as well as tube options to allow for increased operating lengths
- Low axial force ball design resulting in longer lasting high speed operation
- Complete range available from 180 - 3500Nm

Thrust Bearings

Uniquely designed and manufactured by Beattys' in-house team.

KEY STRENGTHS & BENEFITS:

In all marine applications with conventional shaft drives, the thrust along with vibration from the propeller is transmitted axially through the shaft to the coupling, through the transmission, and on to the engine.

Turret thrust bearings designed and manufactured by Beattys provide the perfect solution in absorbing the thrust and vibrations, while also simplifying engine installation and shaft alignment.

Range:

- Thrust capacity from 3 kN to 60 kN
- Standard flange designs to suit split couplings
- Internal taperloc designs to suit up to 4.0" shaft diameter

Specifications:

- Reduces drivetrain noise by up to 50% compared to any direct drive coupling
- All thrust force is absorbed through rubber pads parallel to the propeller shaft
- Allows for softer engine mounts which further reduces vibrations and noise
- Removes prop thrust off the gearbox increasing service intervals and overall lifetime
- Prevents high frequency vibrations from causing wear and damage to the prop shaft drivetrain
- Saves time and reduces costs with less requirements on propeller shaft alignment

Two, four or six bolt models available depending on thrust requirements.

Current models available up to 2000Hp and 60kN of thrust.

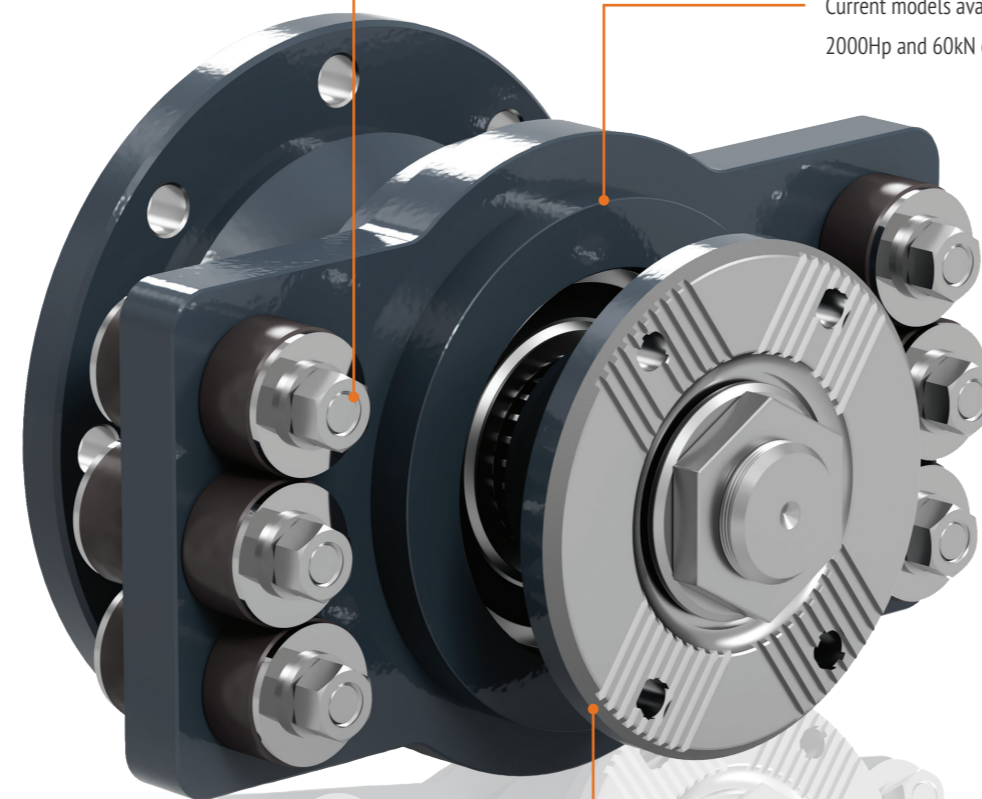

Standard and custom flange bolt patterns available for flexible shaft connections.

Custom designed flanges to connect to any propeller shaft with half coupling machined to suit.

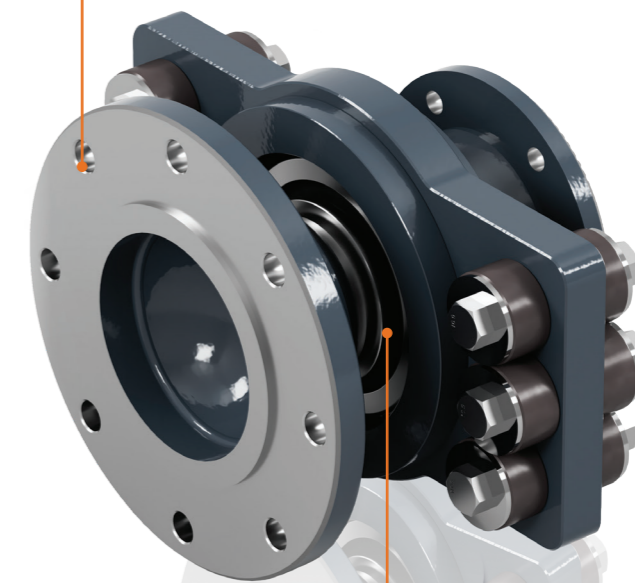

Sealed bearings providing a clean and maintenance-free solution.

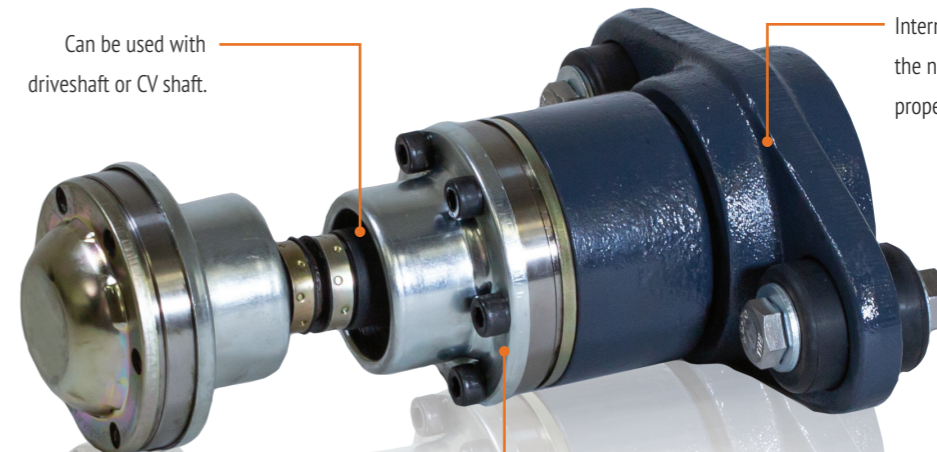

Can be used with driveshaft or CV shaft.

Internal clamp system reducing the need for machining the propeller shaft.

Easy to access greasable bearing for fast and easy servicing.



HART MARINE 17M PILOT VESSEL

VESSEL NAME: TROY EVANS
DESIGNER: PANTOCARENE
BUILDER: HART MARINE
ENGINES: 2 X VOLVO D16 MH
GEARBOXES: 2 X TWIN DISC MGX 5114SC
PROPULSION: 2 X DOEN DJ170HP WATERJETS

PROJECT SUMMARY: Beattys Driveline worked with Pantocarene naval architects to design and manufacture a 2-piece Turret 25 series, marine cardan shaft with centre support bearing, and dynamically balanced to Grade 6.3 for the operating rpm.



HERLEY BOATS 10.2M ELECTRIC CATAMARAN

VESSEL NAME: THE ROCK
DESIGNER: ROGER HILL
BUILDER: HERLEY BOATS
ENGINES: 2 X 100KW PEAK, 60KW CONTINUOUS
BATTERY BANK: 60KWH LITHIUM-ION
PROPULSION: 2 X PROPELLERS

PROJECT SUMMARY: Beattys Driveline was contacted by Herley Boats requiring a low noise compact driveline. Beattys' marine consultants designed and manufactured 2 x Turret TM115 thrust bearing assemblies rated for 8.5kN, including close coupled CV shafts.



NORMAN WRIGHT & SONS 17M PATROL VESSEL

VESSEL NAME: TAMOYA
DESIGNER: INCAT CROWTHER
BUILDER: NORMAN R WRIGHT AND SONS
ENGINES: 2 X MAN 16-850 EPA TIER III
GEARBOXES: 2 X ZF 510V
PROPULSION: 2 X PROPELLERS

PROJECT SUMMARY: Beattys Driveline was approached by Incat Crowther naval architects to design and manufacture a driveline to suit this commercial application vessel. Beattys' technical team designed and manufactured 2 x sealed for life Turret 17 marine cardan shafts.



Q-WEST 30M MUSSEL HARVESTER

VESSEL NAME: VANGUARD
DESIGNER: OCEANTECH NZ LIMITED
BUILDER: Q-WEST BOAT BUILDERS
ENGINES: 2 X SCANIA D113 073M MARINE
GEARBOXES: 2 X ZF360A
PROPULSION: 2 X FIXED PITCH PROPELLERS

PROJECT SUMMARY: Beattys' design team worked with OceanTech marine consultants to design and manufacture 2 x heavy duty Turret 35 marine cardan shafts and 2 x Turret TM150-6 new generation thrust bearing assemblies rated for 38kN.





Beattys
DRIVELINE

DRIVELINE SOLUTIONS TO DRIVE YOUR BUSINESS FURTHER

When it comes to drivelines, at Beattys we get satisfaction from resolving any challenge that comes through our world-class workshop and manufacturing facility. This not only comes from our can do attitude, but is backed by technical expertise, leading-edge manufacturing robotics and advanced design facilities. No matter the project - from a single specialist vehicle to a national fleet - there isn't a driveline problem we can't solve.

+61 2 9098 0435 / enquiries@beattys.com.au / beattys.com.au

100% FAMILY OWNED
FAMILY PROUD