



Unrivalled performance with thrust bearings.

Precision engineered to absorb thrust and vibration for quieter, smoother sailing.

Beattys

THRUST BEARINGS
MARINE

LEADING-EDGE DESIGN INNOVATION

The intelligent design of a driveline is very critical to ensure ongoing reliability. It is important that the power source, speed and universal joint angle are ascertained prior to specifying a shaft to suit any situation. We offer a full consultation and design service so your custom requirements can be met with products that deliver optimal performance.



Turret Driveline is our legacy. With over sixty years of experience, we are New Zealand's most trusted supplier for all driveline needs. Turret drivelines and componentry are designed, and hand built to extremely high standards here in our state-of-the-art Beattys Group Auckland facility, and backed by our dedicated and accessible team.

Benefits of a Turret thrust bearing.

In all marine applications with conventional shaft drives, the thrust and vibration from the propeller is transmitted axially through the shaft to the coupling, through the transmission, and then to the engine.



"As designers of high-end luxury motor yachts, we are always striving to develop and improve our product wherever possible.

In my opinion putting the propeller shaft through a thrust bearing is the ultimate driveline installation. Taking the thrust directly into the structure rather than through engine mounts dramatically reduces vibration and noise.

Beattys are our go-to for anything related to thrust bearings and universal joints that we use whenever the situation and installation allows.

The team at Beattys is very knowledgeable and always deliver the correct solution for each individual project, on time and to the highest standard."

BILL UPFOLD
ELITE MARINE DESIGN LTD

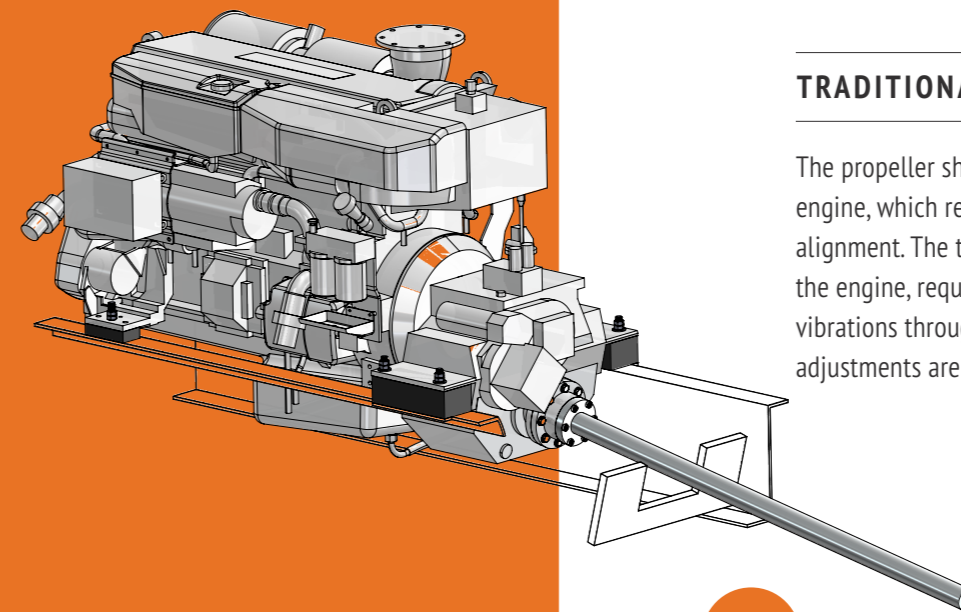

TRADITIONAL INSTALLATION:

The propeller shaft is mounted directly to the gearbox or engine, which requires time consuming and precise laser alignment. The thrust is transferred directly through to the engine, requiring stiff engine mounts which transmit vibrations through to the hull. Regular angle and height adjustments are also required to monitor operational wear.

VS

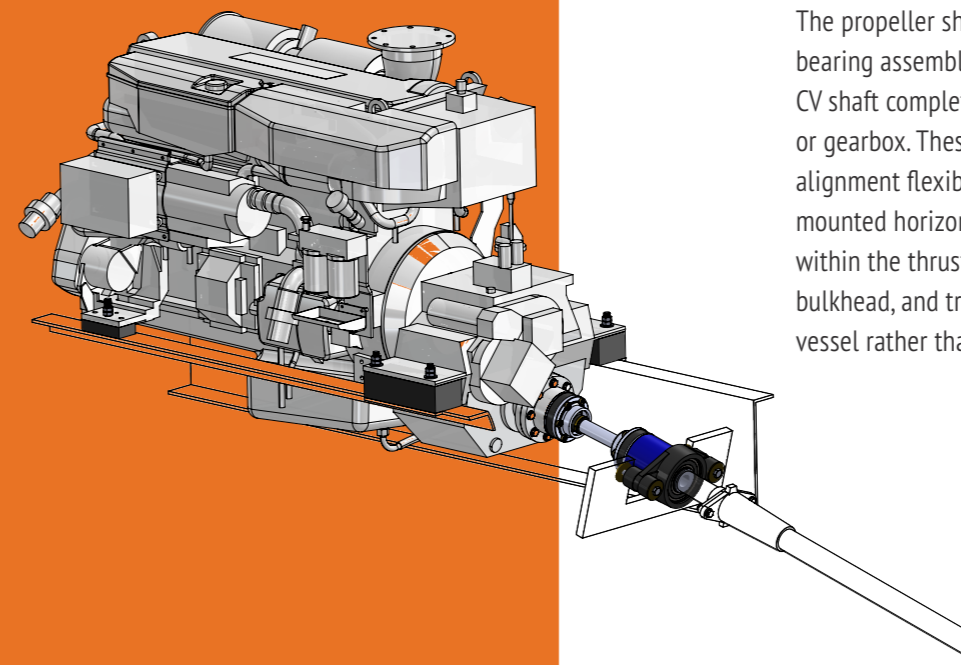

TURRET THRUST BEARING INSTALLATION:

The propeller shaft is mounted directly to the thrust bearing assembly, and then a universal cardan shaft or CV shaft completes the connection through to the engine or gearbox. These installations allow for a wide range of alignment flexibility, including allowing the engine to be mounted horizontal in the vessel. The thrust is absorbed within the thrust bearing assembly shaft of the supporting bulkhead, and transferred directly to the structure of the vessel rather than the engine or transmission.

Specifications.

Uniquely designed and manufactured by Beattys.

BENEFITS:

- Reduces noise – up to 50%
- Prevents high frequency vibrations
- Increases life of drivetrain componentry including cutlass bearings and engine mounts
- Flexibility with engine installation and alignment
- Eliminates regular operational angle adjustment
- Custom flange adapters
- Allows for softer engine mounts which further reduce vibrations and noise
- Removes prop thrust off the gearbox, increasing service intervals and overall lifetime
- Prevents high frequency vibrations from causing wear and damage to the prop shaft drivetrain
- Saves time and reduces costs with less requirements on propeller shaft alignment

RANGE AND CAPACITY:

- Models range from 3kN to 60kN
- Power rating up to 2000Hp
- Internal taperloc designs to suit up to 4.0" propeller shaft diameters
- Pleasure and commercial duty rated

SPECIFICATIONS:

TURRET PART NUMBER	LIMITING SPEED (rpm)	THRUST (kN)	SHAFT MAX DIAMETER (mm)	SHAFT MAX DIAMETER (inches)	MOUNTING PCD (mm)	QTY BUSHES
TM108	5600	6.7	30	1.0	144	2
TM113	4300	10.9	40	2.0	184	2
TM115	4000	13.3	45	2.0	202	2
TM121	2250	17.1	50	2.0	216	2
TM130	1900	19.7	55	2.0	233	2
TM140	2123	28.7	55	2.0	266	4
TM150	1820	38.2	65	3.0	304	6
TM220	1365	61.5	80	3.0	380	8
TM240	1006	61.2	120	5.0	480	4

Two, four or six bolt models available depending on thrust requirements.

Current models available up to 2000Hp and 61kN of thrust.

Custom designed flanges to connect to any propeller shaft with half coupling machined to suit.

Sealed bearings providing a clean and maintenance-free solution.

Standard and custom flange bolt patterns available for flexible shaft connections.

THRUST BEARING SOLUTIONS TO SUIT EITHER CV SHAFT OR CARDAN SHAFT APPLICATIONS:





FAMILY-OWNED COMMITMENT FROM NEW ZEALAND TO THE WORLD

Family-owned businesses have something special. A core value that larger corporations cannot duplicate. When you have three generations of a family involved in a business, there's a genuine desire to look out for those people who work in, for and with the business. And there's a will for the business and our customers to collectively succeed. Since 1963 three generations of our family have given their best to ensure that Beattys Group's reputation as a quality manufacturer, supplier and employer is entrenched with those we value most - our people, our customers and our suppliers.



Innovation in motion.

+64 9 263 7761 / enquiries@beattys.com / beattys.com

100% FAMILY OWNED
FAMILY PROUD