



The driving force behind industry.

Bespoke driveline solutions for global producers and manufacturers.

Beattys

DRIVELINE
INDUSTRIAL

It's the thinking before production that makes our drivelines different.

YOUR PROBLEM. OUR PASSION.

We take problems of complexity and scale and create bespoke driveline solutions to optimise performance. To us, every project is a different proposition – and an opportunity to craft the best solution.

At Beattys we understand that the industrial environment and the demands of the industry present the ultimate challenge for product quality and durability. Our design expertise has been proven time and time again, working with some of the leading industrial corporates in New Zealand and Australia.

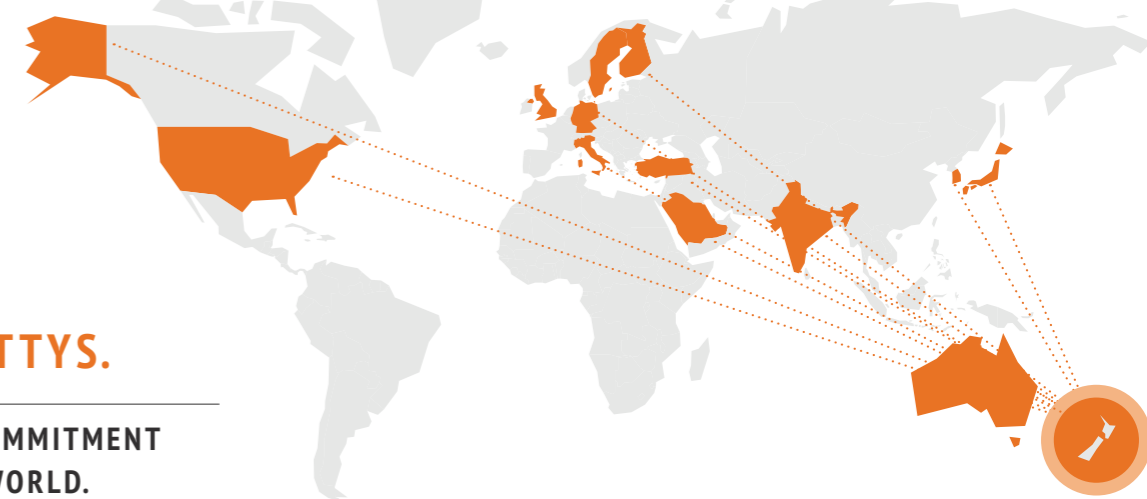

WE ARE BEATTYS.

FAMILY-OWNED COMMITMENT FROM NZ TO THE WORLD.

Family-owned businesses have something special. A core value that larger corporations cannot duplicate. When you have three generations of a family involved in a business, there's a genuine desire to look out for those people who work in, for and with the business. And there's a will for the business and our customers to collectively succeed. Since 1963 three generations of our family have given their best to ensure that Beattys Driveline's reputation as a quality manufacturer, supplier and employer is entrenched with those we value most - our people, our customers and our suppliers.



100% FAMILY OWNED



VIP CUSTOMER SUPPORT



MANUFACTURED IN NZ



QUALITY COMPONENTRY

LEADING-EDGE DESIGN INNOVATION

The intelligent design of a driveline is very critical to ensure ongoing reliability. It is important that the power source, speed and universal joint angle are ascertained prior to specifying a shaft to suit any situation. We offer a full consultation and design service so your custom requirements can be met with products that deliver optimal performance.

STATE-OF-THE-ART MANUFACTURING



Turret Driveline is our legacy. With over sixty years of experience, we are New Zealand's most trusted manufacturer and supplier for all driveline needs. Turret drivelines and componentry are designed and hand built to extremely high standards here in our state-of-the-art Beattys Driveline Auckland facility, and backed by our dedicated and accessible team.

Our attention to your detail

1 ASSESS

Beattys will scope the project, identifying any critical parameters and challenges that we need to overcome to ensure we deliver a premium product.

2 DESIGN

Our team of technical engineers will then design a custom solution using state-of-the-art CAD and programming systems to ensure that we will meet all the client's needs.

3 MANUFACTURE

Throughout our driveline manufacturing process, you can be guaranteed of the highest level of engineering excellence and commitment to quality.

4 BALANCE

All drivelines are dynamically balanced in one of our four, multi-plane balancing machines. We spot-weld any weights to reduce stress on the driveshaft tube.

5 REVIEW

Once a driveline has been dynamically balanced and painted, it goes through a series of rigorous inspections and quality control measures to ensure the products we deliver will fit our commitment to premium quality.

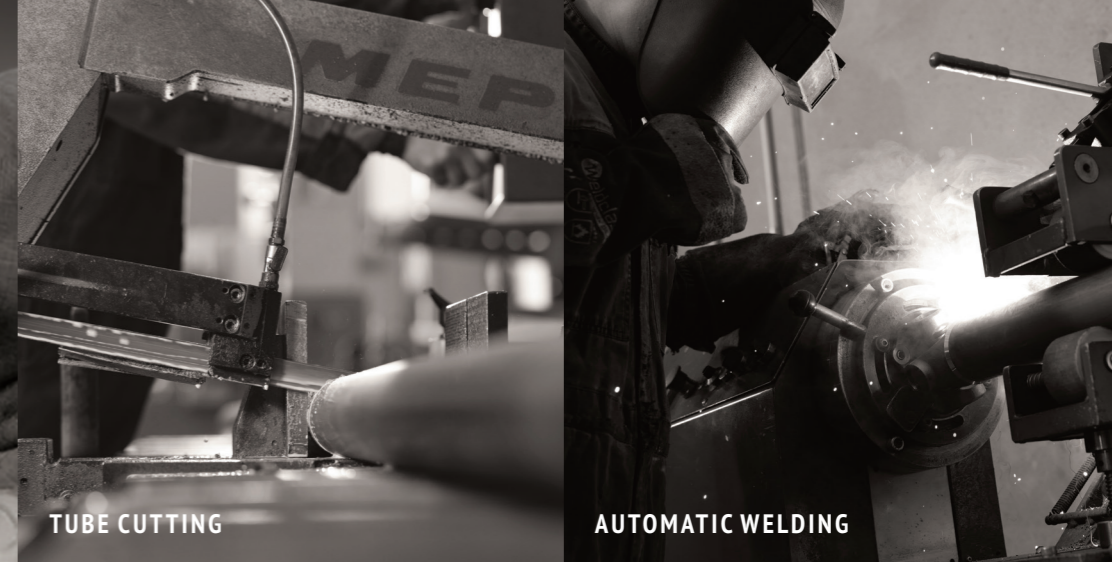

TUBE CUTTING



AUTOMATIC WELDING



ASSEMBLY LINE

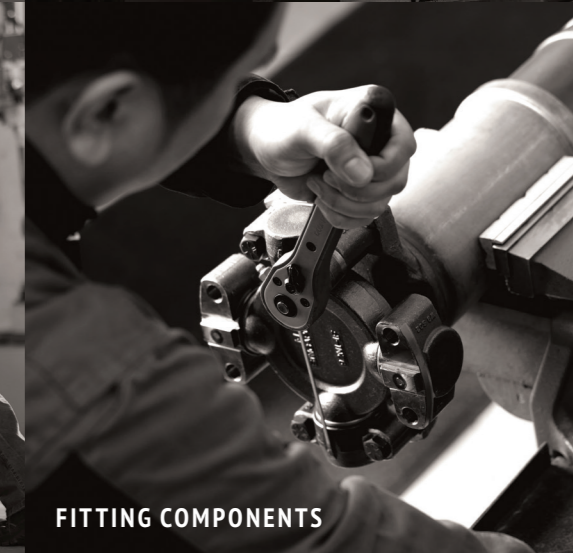

FITTING COMPONENTS



FITTING COMPONENTS



DYNAMIC BALANCING



BALANCE WEIGHT SPOT-WELDING



COATING PLANT

Global supply capabilities

PROJECT CAPACITY

Whether your project is universal couplings for a conveyor system or a large industrial driveshaft to drive rolls in steel mills, Beattys Driveline has the in-house capabilities to design and manufacture industrial drivelines to suit all duty applications; from light to heavy industry.

RAW MATERIAL

More than 30,000 driveshaft components stocked locally in New Zealand make Beattys Driveline one of Australasia's leading driveline specialists.

EXPORT

Supporting our valued global client base, Beattys Driveline despatches componentry and complete drivelines worldwide via our international freight partners.

DRIVELINE RATINGS

200Nm - 750,000Nm torque capacity ratings, and connection flanges from DIN 58mm to DIN 480mm.

Industries we work with

PULP AND PAPER

STEEL
MANUFACTURING

PORT HANDLING

OIL AND GAS

WATER TREATMENT

FOOD PROCESSING

Industrial Driveshafts

Premium driveshaft solutions - Powering industry with optimal performance.

KEY STRENGTHS & BENEFITS:

The demands of the industrial environment provide the ultimate challenge for product quality and durability, along with the need for proven design expertise. Beattys has risen to this challenge and has enjoyed working alongside Australasia's leading manufacturers for many years to assist with their driveline design, and is now the preferred manufacturer and supplier for a number of these corporates.

Beattys Driveline has made a significant investment in specialised equipment and technical know-how training to ensure our team is at the forefront of industry requirements, to deliver excellence and premium driveline solutions. All componentry, processes and workmanship is completed in our own NZ-based workshop, and are of the highest industry standards. Our products are trusted globally by manufacturers that service the steel, wood, recycling and mining industries to name a few.

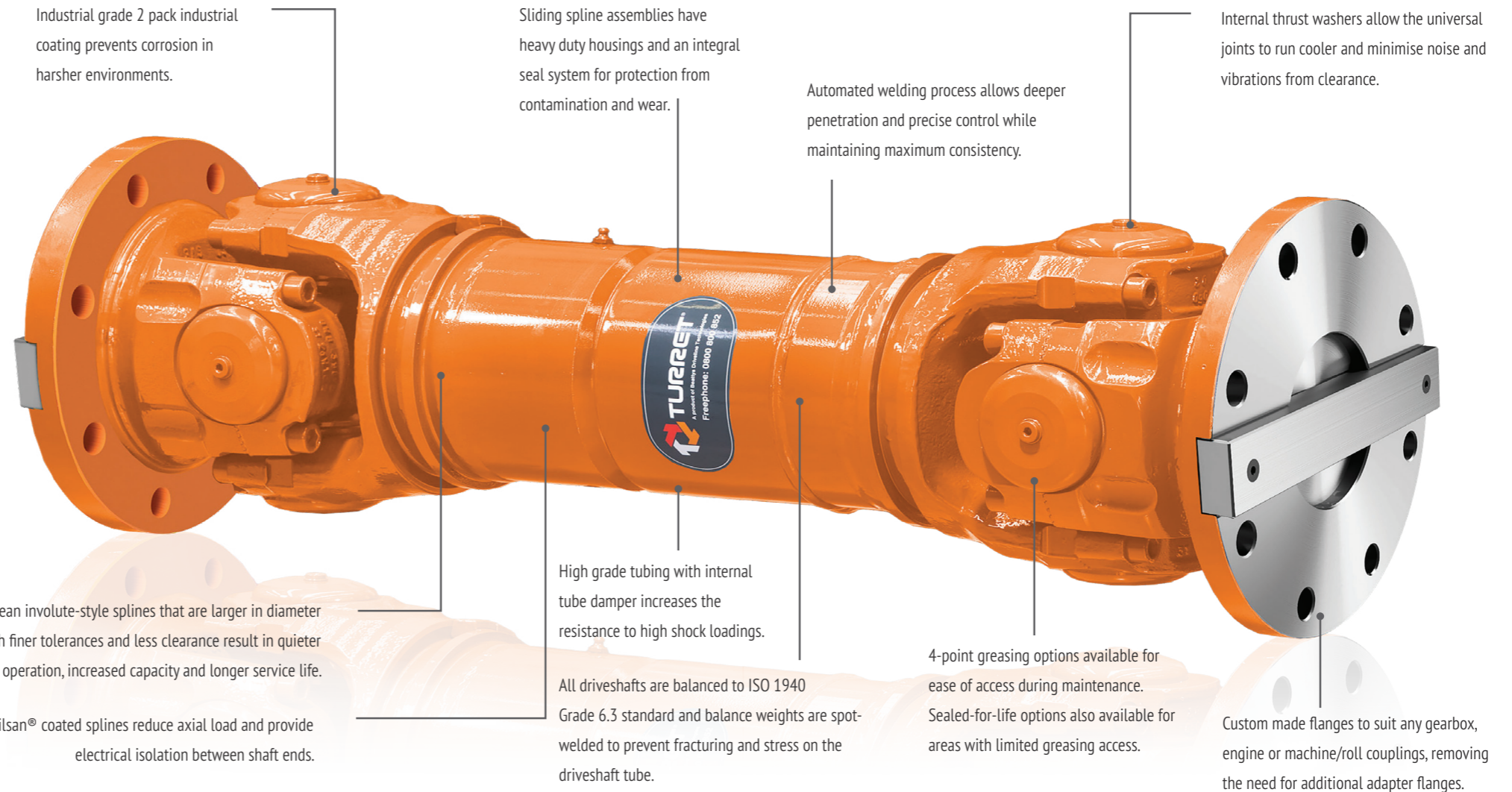

Industrial grade 2 pack industrial coating prevents corrosion in harsher environments.

Sliding spline assemblies have heavy duty housings and an integral seal system for protection from contamination and wear.

Automated welding process allows deeper penetration and precise control while maintaining maximum consistency.

Internal thrust washers allow the universal joints to run cooler and minimise noise and vibrations from clearance.

European involute-style splines that are larger in diameter with finer tolerances and less clearance result in quieter operation, increased capacity and longer service life.

Rilsan® coated splines reduce axial load and provide electrical isolation between shaft ends.

High grade tubing with internal tube damper increases the resistance to high shock loadings.

All driveshafts are balanced to ISO 1940 Grade 6.3 standard and balance weights are spot-welded to prevent fracturing and stress on the driveshaft tube.

4-point greasing options available for ease of access during maintenance. Sealed-for-life options also available for areas with limited greasing access.

Custom made flanges to suit any gearbox, engine or machine/roll couplings, removing the need for additional adapter flanges.

CV Shafts



OVERVIEW

In applications with unequal angles, the introduction of a Turret CV shaft results in higher performance and extended life hours from the low axial force ball design.

SPECIFICATIONS

- Short coupled options for minimal length requirements as well as tube options to allow for increased operating lengths
- Maintenance-free design with high speed rubber boot sealing system
- Complete range available from 180 - 3500Nm

Short Coupled Shafts



Extended Slip Shafts

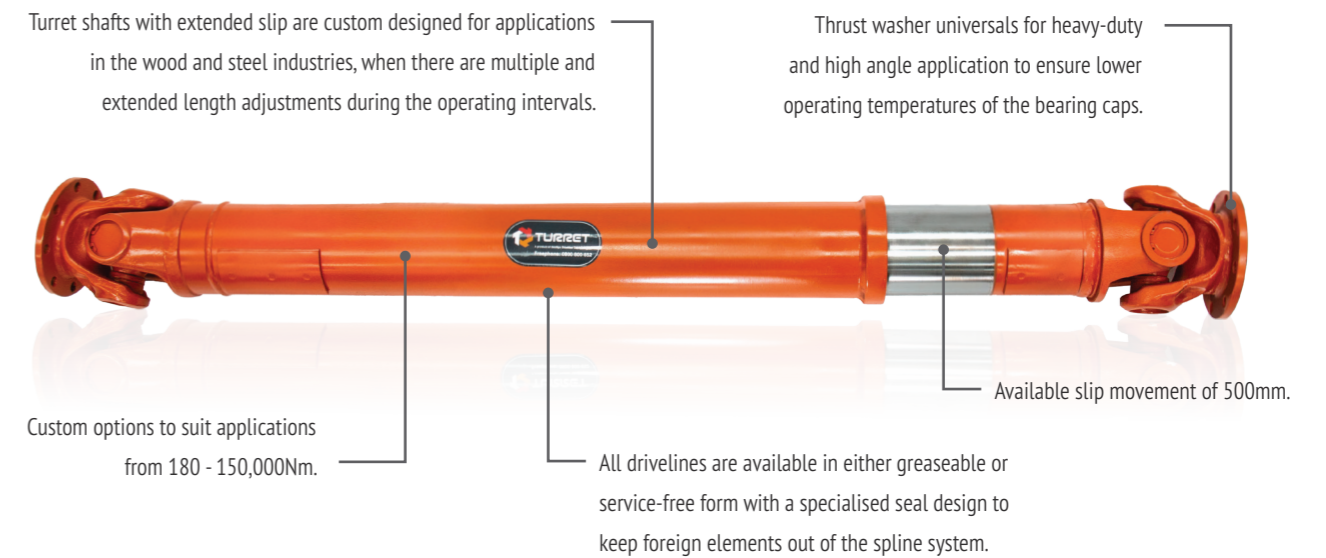

“Beattys for us in one word is reliability. We can trust the product 100%. As a 24/7 operation, we can’t afford anything less.”

STEVE DANIELS
OJI FIBRE SOLUTIONS

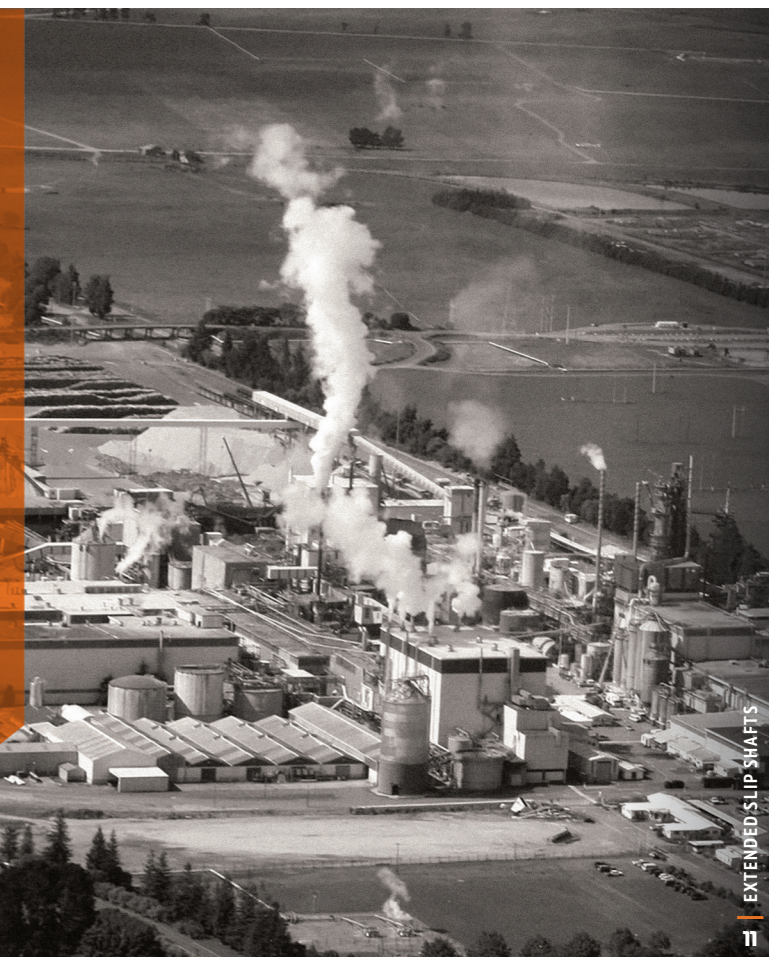

Layrub Couplings

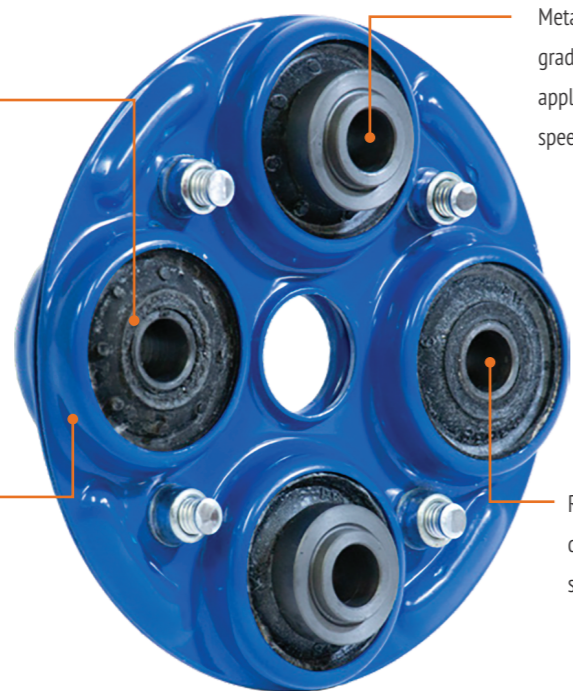

Various rubber inserts available on some models to custom match the torsional stiffness to the individual application.

Metal support housings and high grade rubber inserts allow models for applications up to 5000rpm in high speed applications.

A robust design with a metal housing extends the service life while ensuring maximum performance.

Rubber inserts are designed to handle initial startup shock load.



Best suited to low angle applications below 3°.

Available with complete shaft and sliding spline assembly.

With the system being fully self supported at all rpm ranges, removing the need for additional centre supports.

Precision Couplings



Over 150 different styles and sizes available.

Double joint options for high angle situations up to 50°.

Design tolerances reduce operating wear providing longer service life.

Models rated from 3.5Nm to 720Nm.

Compact designs compared to traditional driveshaft designs.

Solid or pre-machined options available.

Available with precision sliding splines for applications with variable lengths.

Rubber boot kits available for protection from abrasive materials.

3 Different Styles

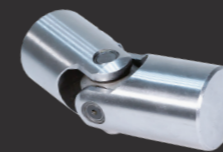

HARDENED BUSH

With precision tolerances and a proven hardening process, these joints are built to perform in lower speed high torque applications, giving the operators peace of mind.



NEEDLE ROLLER

With the introduction of lubricated needle bearings, the expected life of these couplings can be increased by up to 500% in demanding applications.



STAINLESS STEEL

Extend the life of the driveline in corrosive and food grade applications by opting for a full stainless steel precision coupling.

Universal Joints (Industrial Standard)

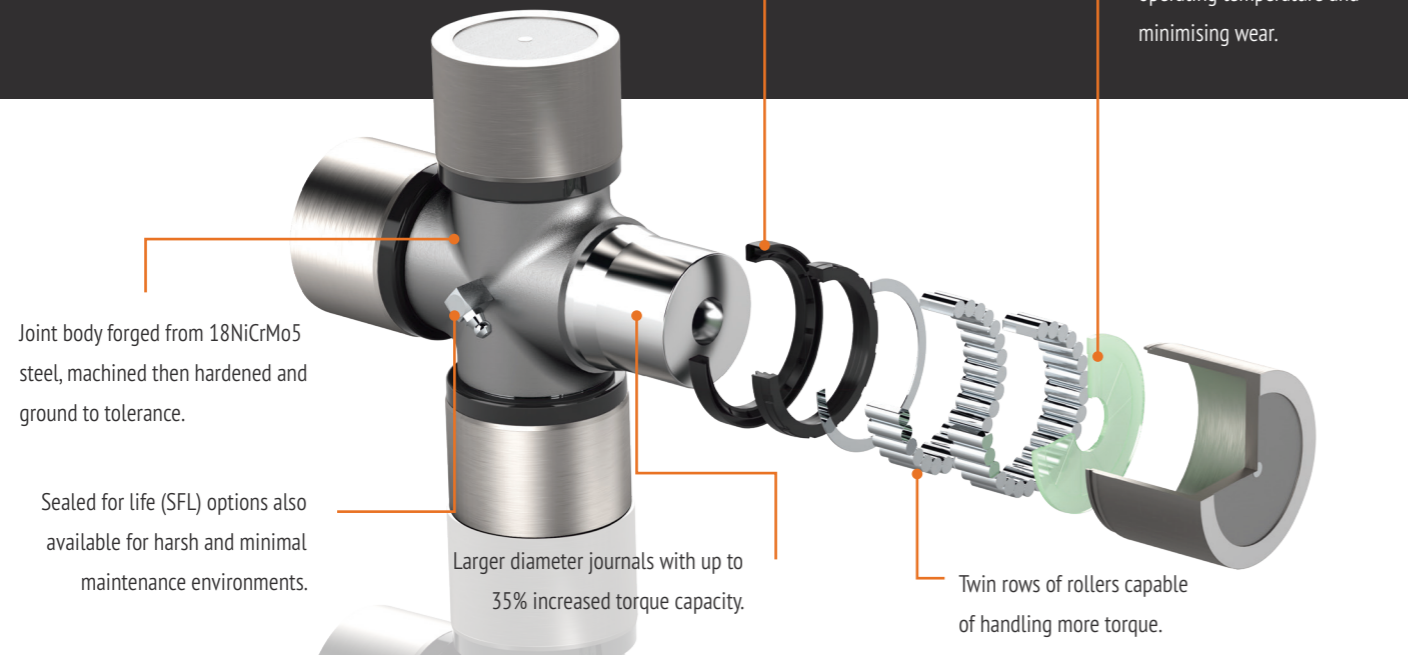

CV Joints



OVERVIEW

Our full suite of constant velocity (CV) joints caters for all types of Industrial applications. All Turret CV joints are sourced from industry leading suppliers and are guaranteed to outperform and out last.

SPECIFICATIONS

- High speed and performance types
- Ideal for difficult angle applications
- Complete range of high speed boots available
- Complete shafts available

Universal Joints (Industrial Heavy)

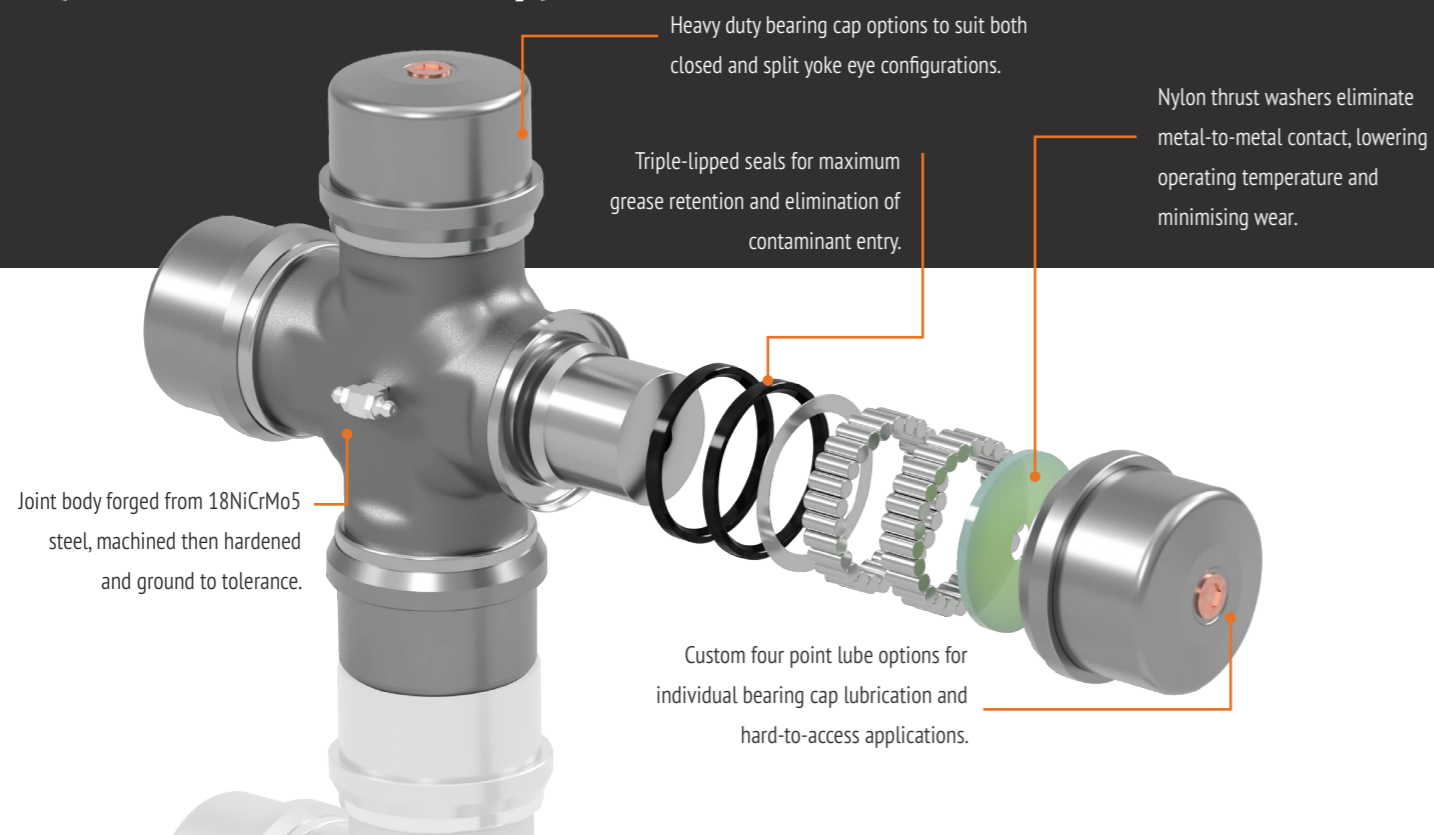

Sliding Spline Sets



OVERVIEW

One of the key components for any driveline is the sliding splines. Any wear on these will result in vibrations and premature wear of other moving components. Beattys hold a complete range of Turret slip sets that suit all applications from automotive to industrial. All splines are thoroughly inspected by one of our engineers before leaving our parts department to ensure we continue to provide a high standard of componentry.

SPECIFICATIONS

- Involute splines - European design
- SAE spline for standard series
- Various spline lengths in each series
- Low noise especially for marine applications

Design



OVERVIEW

The intelligent design of a heavy transport driveline is very critical to ensure ongoing reliability. It is important that the power source, speed and universal joint angle are ascertained prior to specifying a shaft to suit any situation. Whether your requirement is for a precision coupling with less than 7 Nm of torque, or a large equipment shaft with an excess of 80,000 Nm, we offer a full consultation and design service so your custom requirements can be met with products that deliver optimal performance.

SERVICES

- Specifying driveshafts
- Angle and speed calculations
- Driveline layout design and configuration
- Problem solving – vibration, torsional and reliability issues

Reconditioning



OVERVIEW

If a driveshaft has failed, we have the skills and componentry to repair it and get you operational again. We understand that time is always a factor when something unexpected happens, so we always go the extra mile to ensure you are up and running in record time. All repair jobs are tracked through our system, giving our team complete visibility of past and current jobs. This helps us ensure that repairs are engineered to a standard that prevents further issues and failures.

SERVICES

- Urgent overnight and same day repairs
- Heavy duty component upgrades
- Spline replacement
- Re-tubing
- Universal joint replacement
- Yoke replacement
- Centre bearing replacement
- Straightening and re-alignment

Manufacturing



OVERVIEW

We have the internal resources, skills and expertise to produce all types of drivelines for the Industrial industry. Throughout our driveshaft manufacturing process, you can be guaranteed of the highest level of engineering excellence and commitment to quality. All driveshafts we manufacture are then dynamically balanced to ISO 1940 standards to ensure the durability and performance.

SERVICES

- Sealed for life driveshafts
- Short coupled driveshafts
- Two piece driveshafts
- Multi-piece driveshafts
- Centre bearing shafts
- Custom design components
- Custom driveshafts
- Larger OEM production runs
- Multi-piece drivelines
- Industry-specific drivelines

Dynamic Balancing



OVERVIEW

Driveline dynamic balancing is a crucial part of the process to create a lasting solution. With four multi-plane balancers we cover the needs of a diverse range of applications. With drivelines spinning at higher rpm's than ever before, it is important that they are balanced to the finest of tolerances. Our equipment provides the best balance precision by carrying out a simultaneous 4-plane balance at speeds of up to 10000 rpm. All balancing weights are spot welded to ensure an accurate, lasting balance.

SERVICES

- Spot-welded weights to minimise fracturing of driveshaft tube
- Driveline dynamic balance correction
- Driveshaft straightening
- Dynamic balancing reports



BLUESCOPE PORT KEMBLA, AUSTRALIA

PROJECT: Gimbal Shaft for Slag Car

BRIEF: Due to the slag car frame being out of alignment following years of operation, the original gear coupling was working outside of recommended operating angle parameters, therefore resulting in premature wear and component failure.

SOLUTION: Following discussions with Beattys' technical team and Bluescope engineers, Beattys designed a cardan shaft solution with universal joints and integrated sliding spline to manage the variable and increased operating angles. Custom-manufactured flanges to suit the existing drive flanges allowed fitment without modification to existing slag car design. Universal joints were custom fitted with heavy duty thrust washers and sealing system to withstand the operating temperatures in excess of 150°C.



WHAKATĀNE MILL WHAKATĀNE, NEW ZEALAND

PROJECT: Cardan Shaft for Pressing Machine

BRIEF: Following assembly of a new press machine, there were extended lead times for the OEM-supplied drive couplings and lack of technical expertise and communication.

SOLUTION: Beattys' engineers were contacted by the plant managers and following a site visit gathered all the technical duty data, including motor power and roll speeds. A comprehensive design proposal was put forward for a full set of cardan shafts, drive couplings and spares. Following plant approval Beattys were able to manufacture and supply all components in the agreed timeframes, speeding up productivity and minimising downtime.

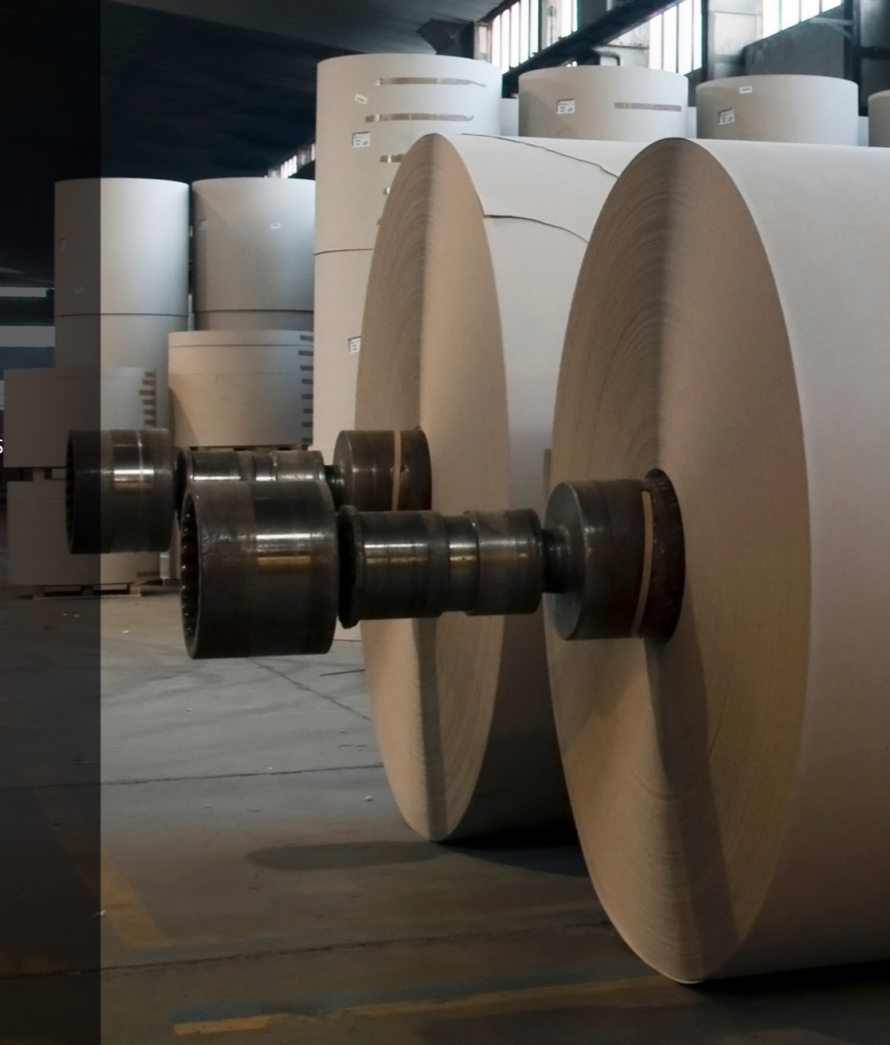

NEW ZEALAND STEEL GLENBROOK PLANT, AUCKLAND

PROJECT: Oscillator Cardan Shaft

BRIEF: NZ Steel was experiencing premature component failure and excessive corrosion from water and steam finding its way into the telescopic sliding spline assembly.

SOLUTION: Beattys' design team visited the plant to identify the environmental factors contributing to the premature failures. Following consultation with the plant engineers, Beattys designed an innovative triple-lip sealing system including a custom stainless steel seal surface area, completely restricting corrosive penetration. Upgrade has resulted in an >300% increase in service life.





Beattys
DRIVELINE

DRIVELINE SOLUTIONS TO DRIVE YOUR BUSINESS FURTHER

When it comes to drivelines, at Beattys we get satisfaction from resolving any challenge that comes through our world-class workshop and manufacturing facility. This comes not only from our can do attitude, but is backed by technical expertise, leading-edge manufacturing robotics and advanced design facilities. No matter the project - from a single specialist application to multi-industrial sites, there isn't a driveline problem we can't solve.

+64 9 263 7761 / enquiries@beattys.com / beattys.com

100% FAMILY OWNED
FAMILY PROUD