



We're here
for the
long haul.

Beattys

DRIVELINE

OUR STORY

100% Family owned.
Family proud.

FROM HUMBLE BEGINNINGS TO A GLOBAL FOOTPRINT

Family owned businesses have something special. A core value that larger corporations cannot duplicate. When you have three generations of a family involved in a business, there's a genuine desire to look out for those people who work in, for and with the business. And there's a will for the business and our customers to collectively succeed. Since 1963 three generations of our family have given their best to ensure that Beattys Group's reputation as a quality manufacturer, supplier and employer is entrenched with those we value most - our people, our customers and our suppliers.

OUR GLOBAL FOOTPRINT



100% FAMILY OWNED

Despite growth and expansion Beattys Group still retains that genuine character.



VIP CUSTOMER SUPPORT

To us here at Beattys every customer is a VIP.



24 HOUR HOTLINE

Any query is just a phone call away.



MANUFACTURED IN NZ

Quality componentry, attention to detail and extremely high manufacturing standards - this is our badge of pride.



QUALITY COMPONENTRY

This goes hand-in-hand with our New Zealand-based manufacturing. We use quality componentry, sourced from the best available suppliers.



GET IN TOUCH

0800 800 852
enquiries@beattys.com
beattys.co.nz

4 HARBOUR RIDGE DRIVE, WIRI, AUCKLAND.

Our state-of-the-art facility conveniently located in Auckland's industrial heartland features the latest in development, manufacturing, engineering and assembly software and hardware. It's also the workplace for some fine people - motivated, hard working and ready with a welcoming smile.



OUR BRAND

Handbuilt for
the hard yards.



“WE HAVE A 10-YEAR RELATIONSHIP WITH BEATTYS WHICH CONTINUES TO THRIVE DUE TO THEIR COMMITMENT, SUPPORT AND ADVANCES IN THEIR PRODUCT.”

SCOTT BRADY

McCARTHY TRANSPORT CONTRACTORS LTD

Turret drivelines and componentry are designed and handbuilt to extremely high standards here in our state-of-the-art Beattys Driveline Auckland facility, and backed by our dedicated and accessible team. Turret drivelines are made to order with pride by Beattys - from a single specialised vehicle to a nationwide fleet - to drive your business further.

- World-leading componentry
- Handcrafted in New Zealand by Beattys
- Backed by Beattys customer support
- Inhouse technical and design team

Generations of expertise.

Since 1963 we've lived and breathed drivelines. Over that period we have partnered with thousands of businesses across New Zealand and abroad to supply the answers to their driveline needs.

Our complete range of driveline solutions is backed by generations of expertise, knowledge and support. Our accessible team will go the extra mile to ensure your fleet performs to its maximum potential. From our state-of-the-art factory we handle it all, from customised design and manufacturing with our Turret brand, to driveline restoration and balancing.

Contents

DESIGN	6
MANUFACTURING	6
TECHNICAL SUPPORT	7
RECONDITIONING	8
DYNAMIC BALANCING	8
MODIFICATIONS	9
COMPLETE DRIVESHAFTS	10-37
COMPONENTRY	38-53
INDUSTRIAL BALANCING	54-59



Design

OVERVIEW

The intelligent design of a driveline is very critical to ensure ongoing reliability. It is important that the power source, speed and universal joint angle are ascertained prior to specifying a shaft to suit any situation. Whether your requirement is for a precision coupling with less than 7 Nm of torque, or a large industrial shaft with an excess of 650,000 Nm, we offer a full consultation and design service so your custom requirements can be met with products that deliver optimal performance.

SERVICES

- Specifying driveshafts
- Angle and speed calculations
- Driveline layout design and configuration
- Problem solving – vibration, torsional and reliability issues



Technical Support

OVERVIEW

With our technicians and sales personnel having over 120 years of combined experience in the driveline industry, we are more than capable of providing technical support when needed. This can include onsite visits to investigate and troubleshoot client issues which are then resolved inhouse to provide a lasting solution.

SERVICES

- Upgrading underperforming driveshafts
- Professional data analysis
- Accurate specification
- Marine TVA calculations
- Engineering certificates

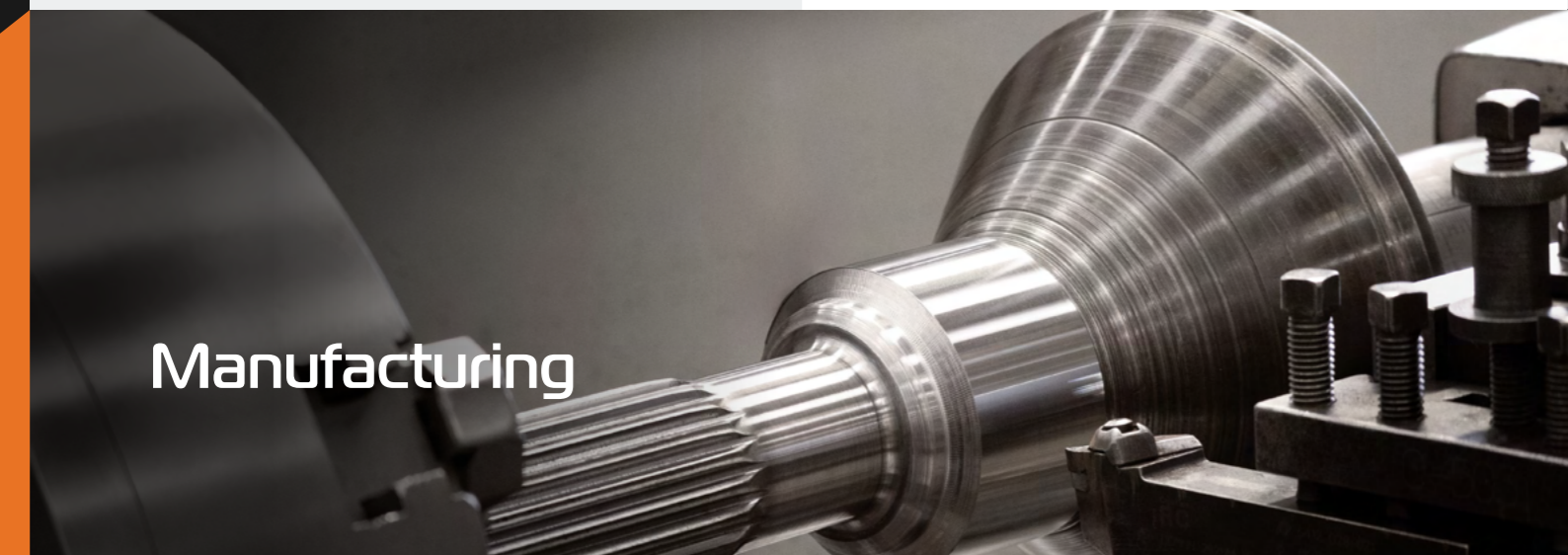

Manufacturing

OVERVIEW

We have the internal resources, skills and expertise to produce all types of drivelines from small automotive through to large industrial driveshafts. Throughout our driveshaft manufacturing process, you can be guaranteed of the highest level of engineering excellence and commitment to quality. All driveshafts we manufacture are then dynamically balanced to ISO 1940 standards to ensure the durability and performance.

SERVICES

- Sealed for life driveshafts
- Short coupled driveshafts
- Two piece driveshafts
- Multi-piece driveshafts
- Centre bearing shafts
- Custom design components
- Custom driveshafts
- Larger OEM production runs
- Multi-piece drivelines
- Industry-specific drivelines



Reconditioning

OVERVIEW

If a driveshaft has failed, we have the skills and componentry to repair it and get you operational again. We understand that time is always a factor when something unexpected happens, so we always go the extra mile to ensure you are up and running in record time. All repair jobs are tracked through our system, giving our team complete visibility of past and current jobs. This helps us ensure that repairs are engineered to a standard that prevents further issues and failures.

SERVICES

- Urgent overnight and same day repairs
- Spline replacement
- Re-tubing
- Universal joint replacement
- Yoke replacement
- Centre bearing replacement
- Straightening and re-alignment

Modifications

OVERVIEW

Due to the wide range of special purpose vehicles and equipment needed to meet the demands of many industries, we offer a modification service for all types of drivelines including shortening, lengthening of driveshafts and changing drive ends. This service is often used in applications such as chassis length adjustments and transmission or engine upgrades.

SERVICES

- Driveshaft shortening
- Driveshaft lengthening
- Changing flange and yoke connections
- Upgrading for higher power ratings and heavy duty applications
- Enhanced greasing systems

Dynamic Balancing

OVERVIEW

Driveline dynamic balancing is a crucial part of the process to create a lasting solution. We use four driveshaft balancers and four industrial balancing machines to cover the needs of a diverse range of applications. With drivelines spinning at higher rpm's than ever before, it is important that they are balanced to the finest of tolerances. Our equipment provides the best balance precision by carrying out a simultaneous 4-plane balance at speeds of up to 5000 rpm. All balancing weights are spot-welded to ensure an accurate, lasting balance.

SERVICES

- Spot-welded weights to minimise fracturing of driveshaft tube
- Driveline dynamic balance correction
- Driveshaft straightening
- Balancing reports

“PACIFIC STEEL HAS BEEN USING THE SERVICES OF BEATTYS’ DRIVELINE DIVISION FOR OVER 25 YEARS, AND THEIR SERVICE HAS BEEN COMMENDABLE. THEIR MAINTENANCE WORK ON OUR MAIN MILL STAND DRIVESHAFTS HAS ALWAYS BEEN TO A VERY HIGH STANDARD WITH QUALITY PARTS; AND ALWAYS EFFICIENT AND ON TIME.”

JOHN ALLEN
PACIFIC STEEL

Complete Driveshafts

AUTOMOTIVE DRIVESHAFTS	12
HEAVY TRANSPORT DRIVESHAFTS	16
MINING & OFF HIGHWAY DRIVESHAFTS	20
INDUSTRIAL DRIVESHAFTS	24
AGRICULTURE DRIVESHAFTS	28
MARINE DRIVESHAFTS	32

Automotive Driveshafts

Premium driveshaft solutions - The drive behind performance.

KEY STRENGTHS & BENEFITS:

Beattys' coverage and expertise within the automotive sector sets us apart as a clear market leader. Due to the long association and rapport established with vehicle manufacturers and their dealerships, Beattys automotive specialists have been called on by many respected car manufacturers to problem solve and develop specific driveline solutions for their market requirements. Beattys provides the automotive industry a complete package with the Beattys technology team taking care of your automotive driveshaft repairs and servicing for all makes and models. Beattys componentry maintains a comprehensive inventory of replacement automotive driveshaft parts to suit all makes and models, both past and present.

Savings: Instead of being faced with the outlay of full OEM replacement, the Beattys technology team has the specialised equipment and technical know-how to repair, replace and upgrade the worn components, delivering substantial savings and benefits.

Reliability: All componentry, processes and workmanship are of the highest industry standards to ensure that Beattys-supplied drivelines meet or exceed OEM specifications and tolerances.

100% QUALITY COMMITMENT



Upgraded and reinforced yoke design to prevent catastrophic failure.

All driveshafts are coated in a premium anti-corrosive paint to ensure they are protected from the elements throughout their life.

Premium automated welds allow for deep penetration and precise control while keeping maximum consistency.

Upgraded splines with increased spline engagement resulting in a more durable longer lasting driveline.

All driveshafts are balanced to ISO 1940 standard and balance weights are spot-welded to prevent fracturing and stress on the driveshaft tube.

Replacement or upgraded driveshaft tube with thicker walls and larger diameters to allow for higher torque applications and increase the resistance to high shock loadings.

Worn centering bush replacements.

Internal circlip, external circlip and staked universal joints meet or exceed OEM specification and are fitted to suit multiple applications.

Large range of rubber couplings for all automotive applications.



Two Piece Shafts

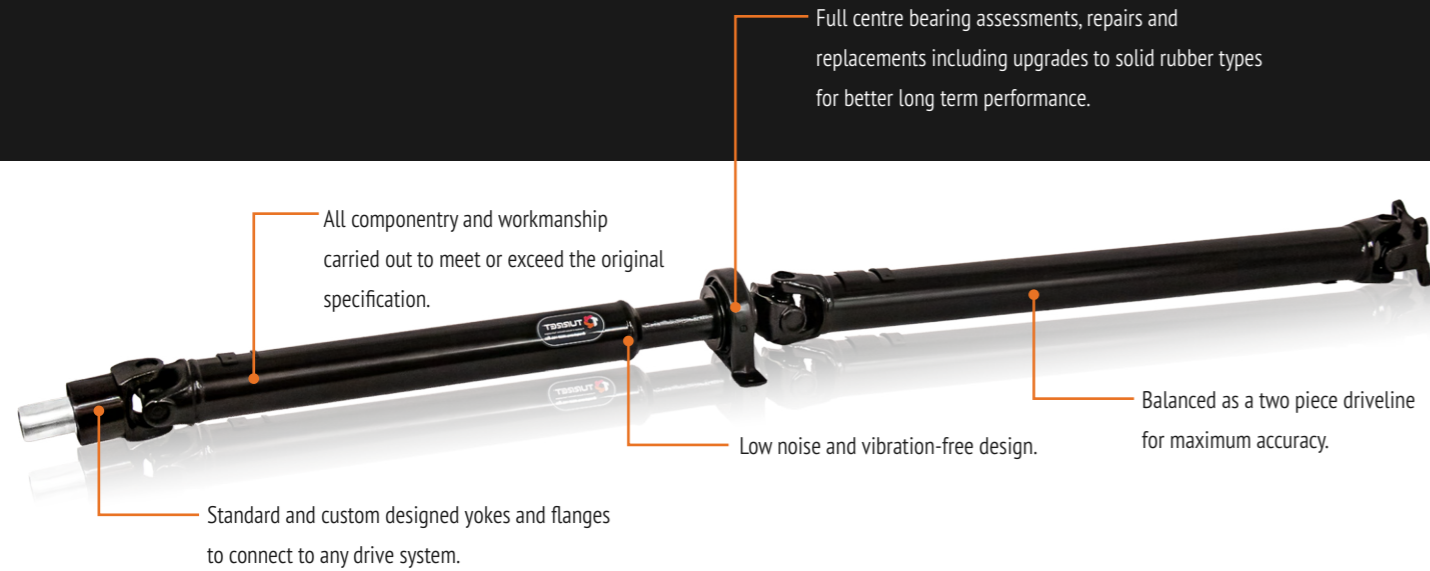

Steering Shafts



Performance Shafts

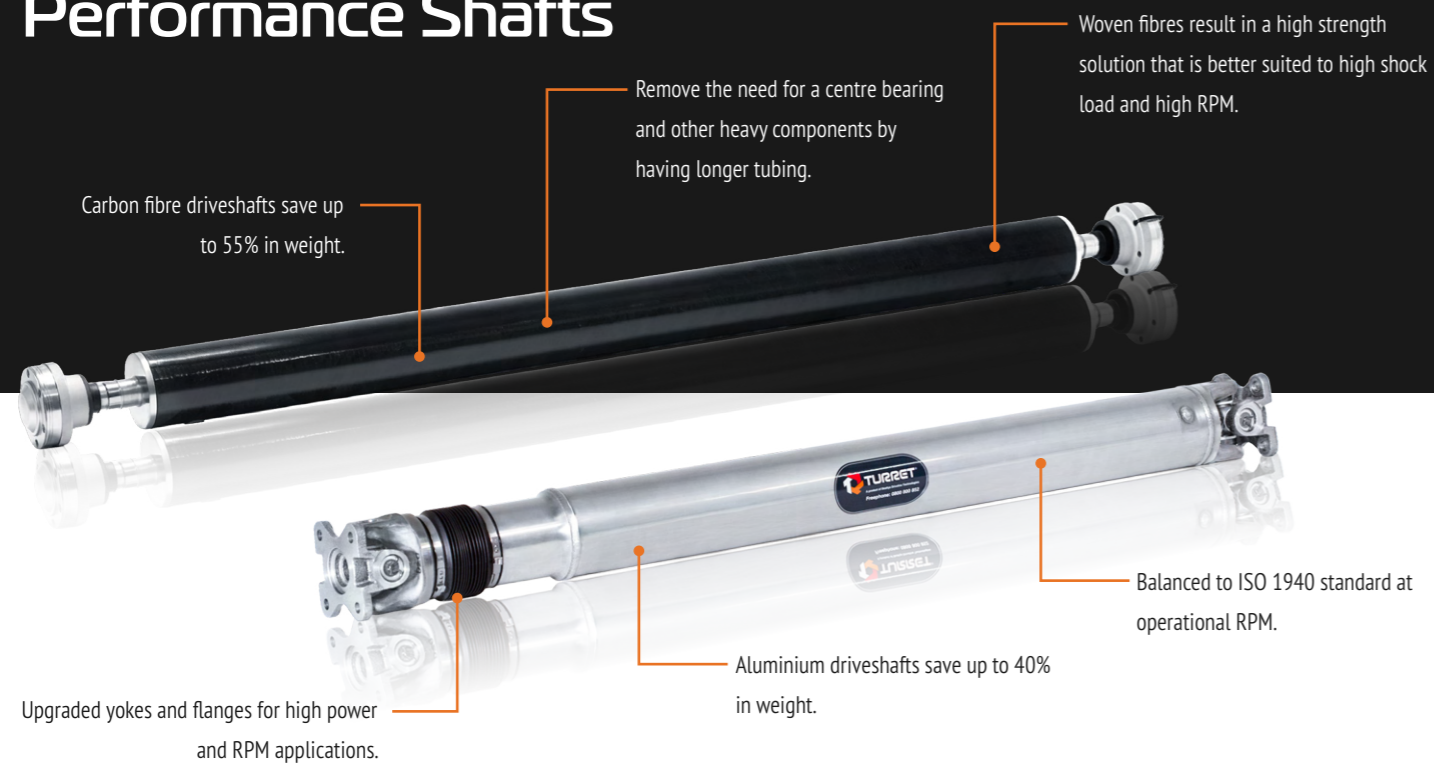

Double Cardan Shafts



Heavy Transport Driveshafts

Premium driveshaft solutions - Reliability for the long haul.

KEY STRENGTHS & BENEFITS:

The heavy transport and logistics industry is a key player in our economy, bringing the world's goods to our door and delivering both people and products to their destinations, locally and around the globe. Beattys Driveline knows how vital it is to keep these trucks, trailers and buses on the road and has been servicing this sector as a core market for many decades.

Instead of being faced with the outlay of full OEM replacement, Beattys Driveline has the specialised equipment and technical know-how to meet or exceed OEM specifications while delivering substantial savings and benefits.

All componentry, processes and workmanship are of the highest industry standards and trusted by commercial transport operators nationwide to deliver reliable, consistent performance.



All driveshafts are balanced to ISO 1940 standard and balance weights are spot-welded to prevent fracturing and stress on the driveshaft tube.

Premium automated welds allow for deep penetration and precise control while keeping maximum consistency.

High grade tubing increasing the resistance to high shock loadings.

Upgraded and reinforced yoke designs to prevent catastrophic failure.

Beattys can replace or upgrade sliding spline assemblies to have heavy-duty housings and integral seal systems that protect from contamination and wear.

Upgraded to European style splines that are larger in diameter with finer splines resulting in increased capacity and longer service life.

Universal joints have premium grade lubricant or service free 'lube-for-life' options.



Hanger Bearing Shafts

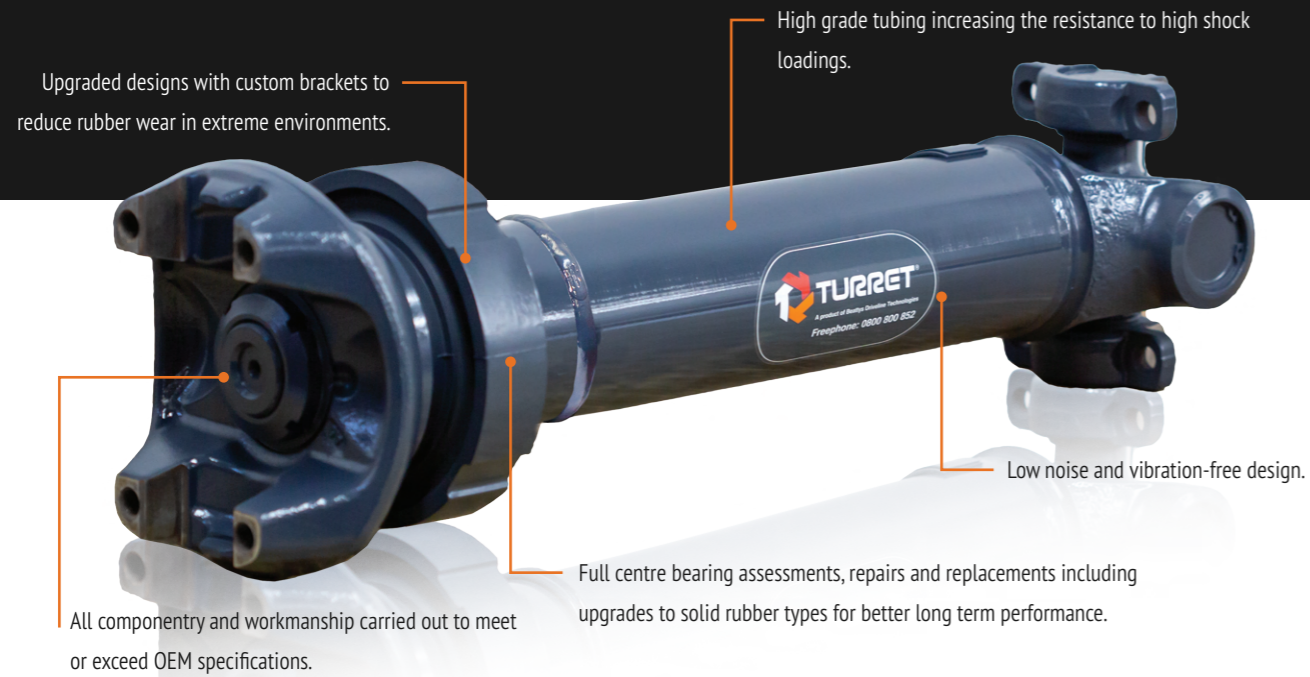

Steering Shafts



ALL STAKED UNIVERSAL JOINTS FITTED TO EXCEED OEM SPECIFICATIONS

Inter Axle Shafts

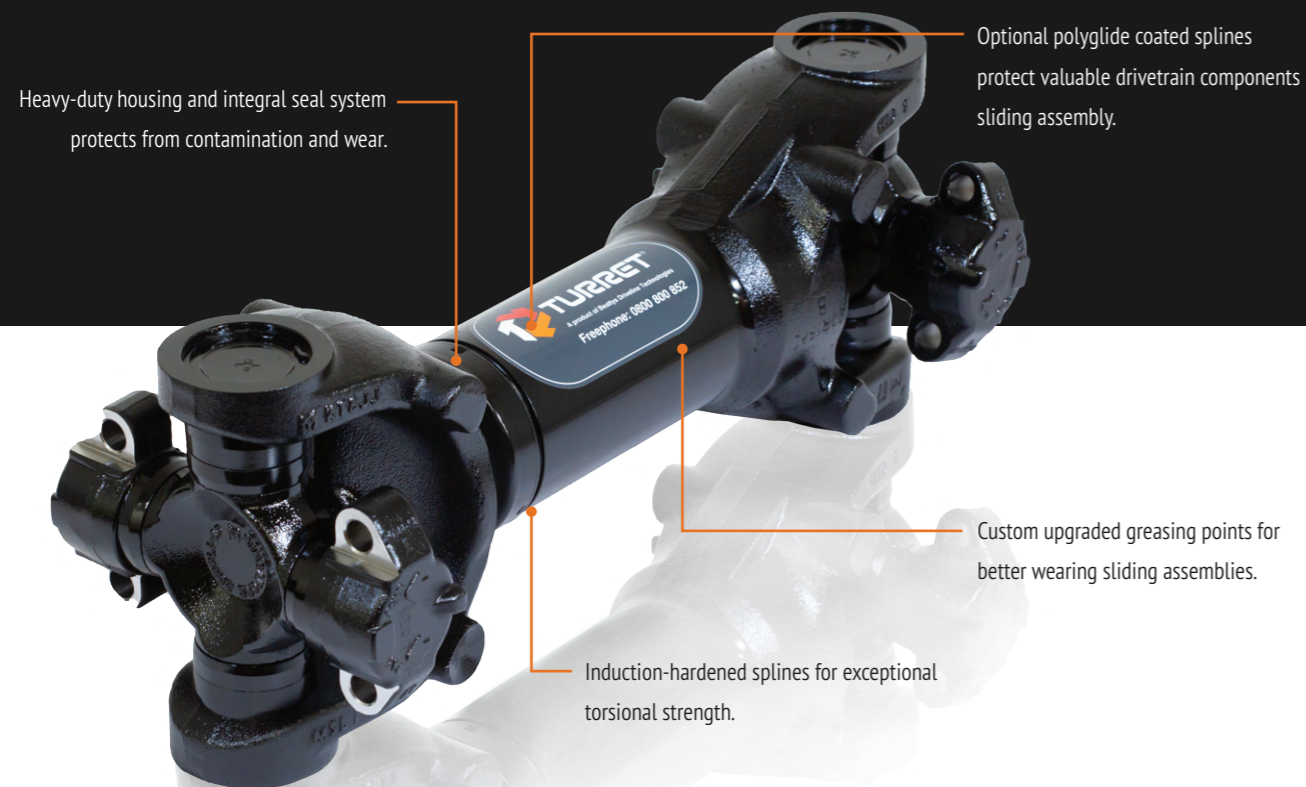

PTO Shafts



Mining & Off Highway Driveshafts

Premium driveshaft solutions - Engineered for extremes.

KEY STRENGTHS & BENEFITS:

Throughout New Zealand machinery and equipment is relied upon to keep our primary industries and key commodity exports moving – that's why Beattys Driveline is trusted as an essential service provider to the agriculture, earthmoving, forestry, infrastructure and mining industries. We have three specialist teams to cover all your driveline and rotating equipment needs: our componentry team keeps all your driveshaft wearing parts on hand, ready for overnight despatch while our driveline engineers take care of repairs, servicing and modifications. Our Beattys balancing team complements the service lineup by offering dynamic balancing and associated repairs for all off-highway rotating equipment such as rotors, fans & harvester drums.

Beattys Driveline has the specialised equipment and technical know-how to meet or exceed all required specifications while delivering substantial savings and benefits.

All componentry, processes and workmanship are of the highest industry standards and trusted by commercial transport operators nationwide to deliver reliable, consistent performance.



Premium automated welds allow for deep penetration and precise control while keeping maximum consistency.

Upgraded to European style splines that are larger in diameter with finer splines resulting in increased capacity and longer service life.

All driveshafts are balanced to ISO 1940 standard and balance weights are spot-welded to prevent fracturing and stress on the driveshaft tube.

Custom designed yokes to suit specialty heavy duty or high angle applications.

Universal joints have premium grade lubricant or service free 'lube-for-life' options.

Beattys can replace or upgrade sliding spline assemblies to have heavy-duty housings and integral seal systems that protect from contamination and wear.

Upgraded and reinforced yoke designs to prevent catastrophic failure.



Driveshafts



All driveshafts are balanced to ISO 1940 standard and balance weights are spot-welded to prevent fracturing and stress on the driveshaft tube.

Beattys can replace or upgrade sliding spline assemblies to have heavy-duty housings and integral seal systems that protect from contamination and wear.

Premium automated welds allow for deep penetration and precise control while keeping maximum consistency.

High grade tubing increasing the resistance to high shock loadings.

Upgraded and reinforced yoke designs to prevent catastrophic failure.

Upgraded to European style splines that are larger in diameter with finer splines resulting in increased capacity and longer service life.

Universal joints have premium grade lubricant or service free 'lube-for-life' options.

Double Cardan Shafts



Extra long spline engagement options for pivot applications.

Short compact options available for space limited applications.

SAE and DIN connecting flange options.

Smoother rotational power flow and longer life at higher operating angles.

Hanger Bearing Shafts



Custom designed yokes and flanges to suit a large range of applications.

Heavy duty bearings and housings designed to handle harsh conditions.

All componentry and workmanship carried out to meet or exceed original specification.

Upgraded yokes with increased support and torque capacity at potential fracture points.

Flexible rubber housings also available according to OEM specifications.

Short Coupled Shafts

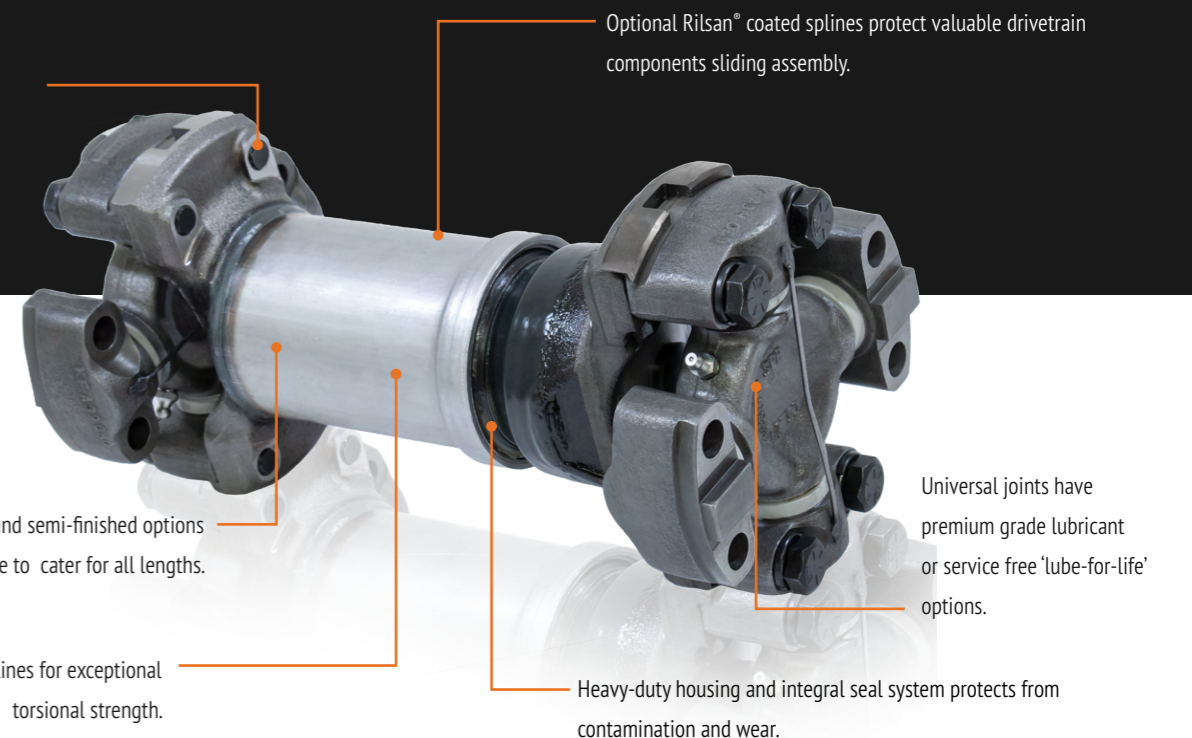

Custom designed yokes to suit specialty heavy duty or high angle applications.

Finished and semi-finished options available to cater for all lengths.

Induction-hardened splines for exceptional torsional strength.

Optional Rilsan® coated splines protect valuable drivetrain components sliding assembly.

Universal joints have premium grade lubricant or service free 'lube-for-life' options.

Heavy-duty housing and integral seal system protects from contamination and wear.

Industrial Driveshafts

Premium driveshaft solutions - Powering industry with optimal performance.

KEY STRENGTHS & BENEFITS:

The demands of the industrial environment provide the ultimate challenge for product quality and durability, along with the need for proven design expertise. Beattys has risen to this challenge and has enjoyed working alongside Australasia's leading manufacturers for many years to assist with their driveline design, and is now the preferred manufacturer and supplier for a number of these corporates.

Beattys Driveline has made a significant investment in specialised equipment and technical know-how training to ensure our team is at the forefront of industry requirements, to deliver excellence and premium driveline solutions. All componentry, processes and workmanship is completed in our own NZ-based workshop, and are of the highest industry standards. Our products are trusted globally by manufacturers that service the steel, wood, recycling and mining industries to name a few.

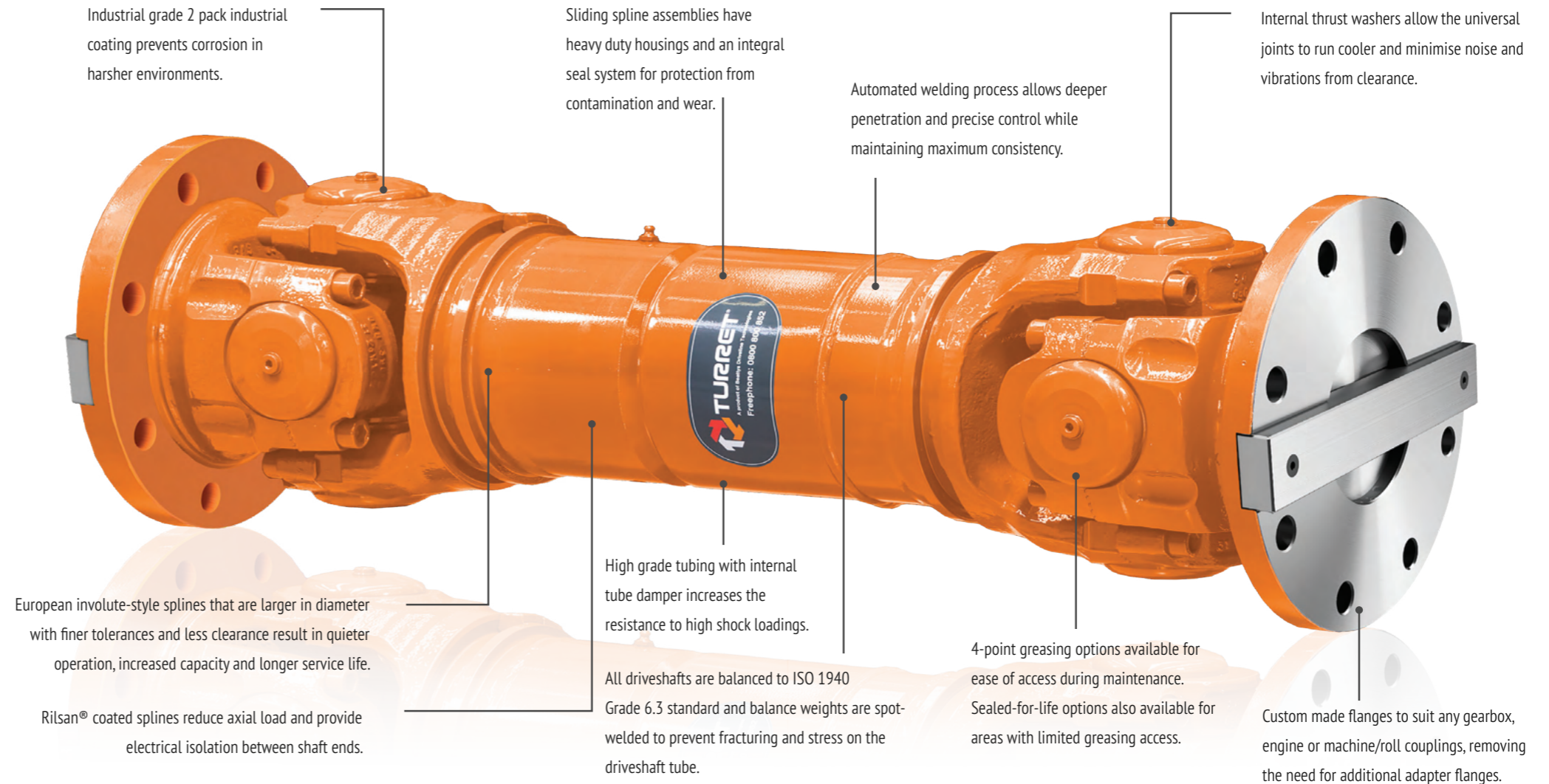

Industrial grade 2 pack industrial coating prevents corrosion in harsher environments.

Sliding spline assemblies have heavy duty housings and an integral seal system for protection from contamination and wear.

Automated welding process allows deeper penetration and precise control while maintaining maximum consistency.

Internal thrust washers allow the universal joints to run cooler and minimise noise and vibrations from clearance.

European involute-style splines that are larger in diameter with finer tolerances and less clearance result in quieter operation, increased capacity and longer service life.

Rilsan® coated splines reduce axial load and provide electrical isolation between shaft ends.

High grade tubing with internal tube damper increases the resistance to high shock loadings.

All driveshafts are balanced to ISO 1940 Grade 6.3 standard and balance weights are spot-welded to prevent fracturing and stress on the driveshaft tube.

4-point greasing options available for ease of access during maintenance. Sealed-for-life options also available for areas with limited greasing access.

Custom made flanges to suit any gearbox, engine or machine/roll couplings, removing the need for additional adapter flanges.

CV Shafts

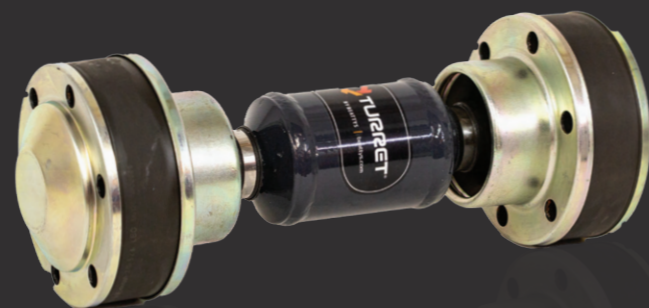

OVERVIEW

In applications with unequal angles, the introduction of a Turret CV shaft results in higher performance and extended life hours from the low axial force ball design.

SPECIFICATIONS

- Short coupled options for minimal length requirements as well as tube options to allow for increased operating lengths
- Maintenance-free design with high speed rubber boot sealing system
- Complete range available from 180 - 3500Nm

Short Coupled Shafts



Extended Slip Shafts

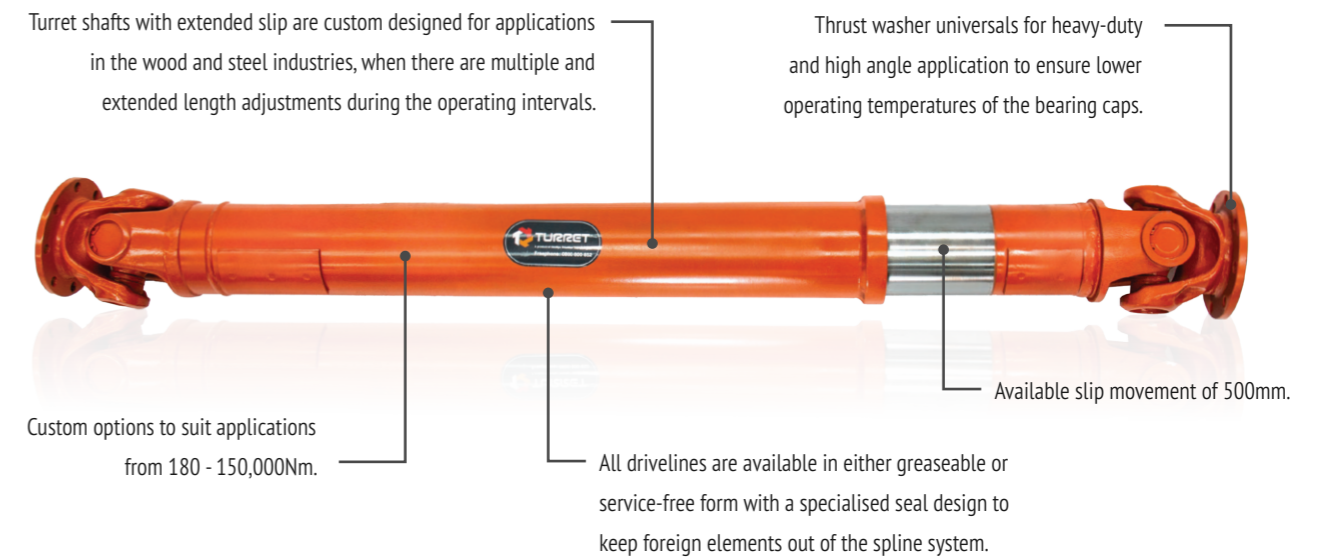

“Beattys for us in one word is reliability. We can trust the product 100%. As a 24/7 operation, we can’t afford anything less.”

STEVE DANIELS
OJI FIBRE SOLUTIONS

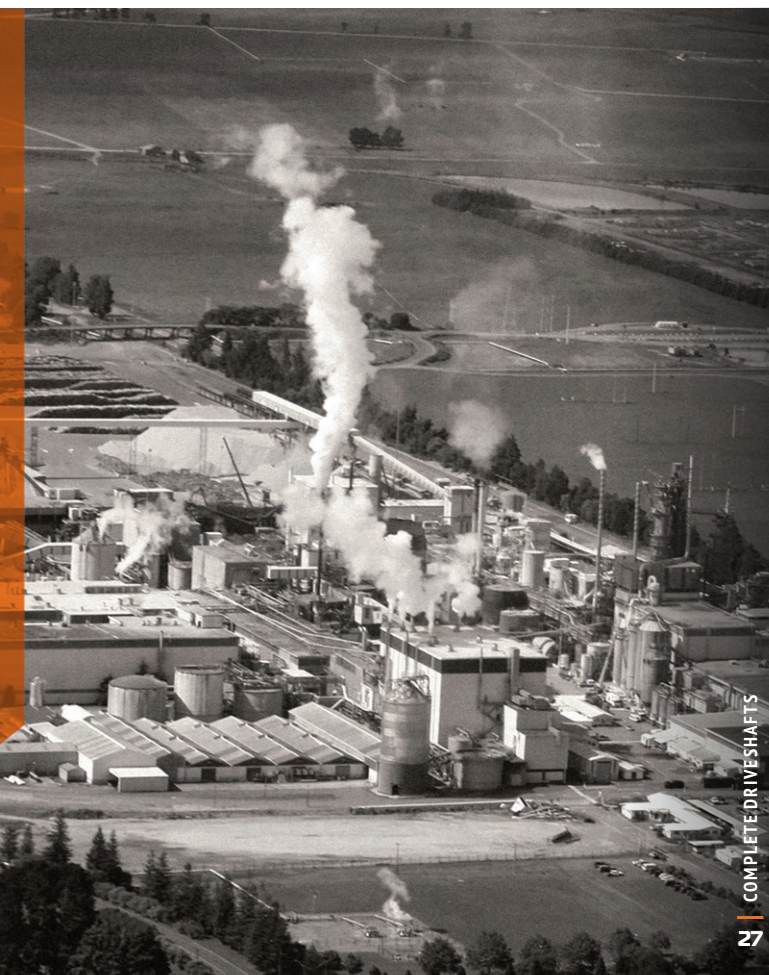

Agricultural Driveshafts

Premium driveshaft solutions - Built for the toughest terrain.

KEY STRENGTHS & BENEFITS:

Throughout Australasia, agricultural machinery and equipment is relied upon to keep our primary industries and key commodity exports moving – that’s why Beattys Driveline is trusted as an essential service provider to the agriculture industry. We have three specialist teams to cover all your driveline and rotating equipment needs: our componentry team keeps all your driveshaft wear parts on hand, ready for overnight despatch while our driveline engineers take care of repairs, servicing and modifications. Our Beattys balancing team complements the service lineup by offering dynamic balancing and associated repairs for all agriculture rotating equipment such as flail rotors, fans & harvester drums.

Instead of being faced with the outlay of full OEM replacement, Beattys Driveline has the specialised equipment and technical know-how to meet or exceed OEM specifications while delivering substantial savings and benefits.

All componentry, processes and workmanship are of the highest industry standards and trusted by equipment asset managers and operators nationwide to deliver reliable, consistent performance.

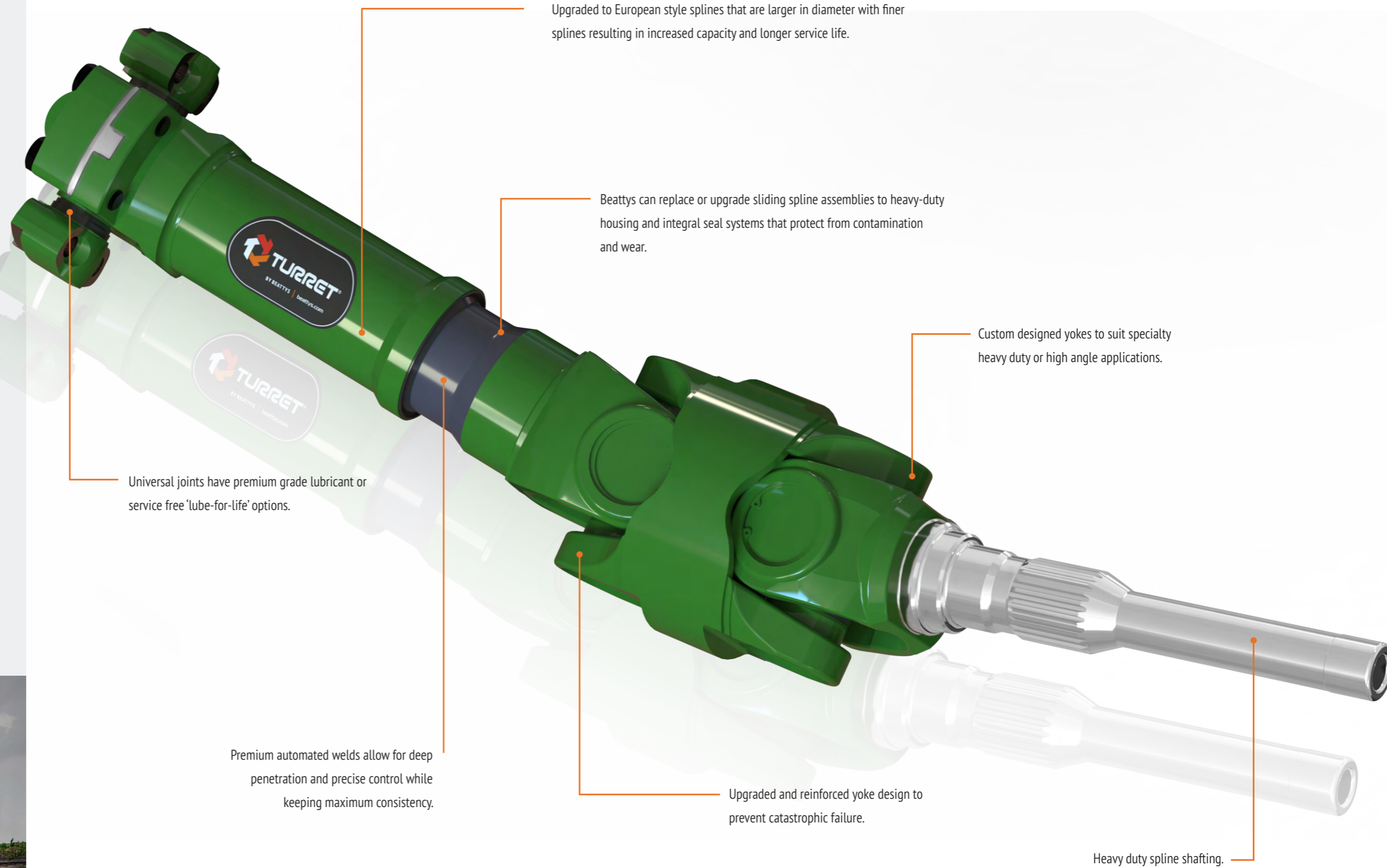

Upgraded to European style splines that are larger in diameter with finer splines resulting in increased capacity and longer service life.

Beattys can replace or upgrade sliding spline assemblies to heavy-duty housing and integral seal systems that protect from contamination and wear.

Custom designed yokes to suit specialty heavy duty or high angle applications.

Universal joints have premium grade lubricant or service free 'lube-for-life' options.

Premium automated welds allow for deep penetration and precise control while keeping maximum consistency.

Upgraded and reinforced yoke design to prevent catastrophic failure.

Heavy duty spline shafting.



Axle Shafts (Heavy Duty)

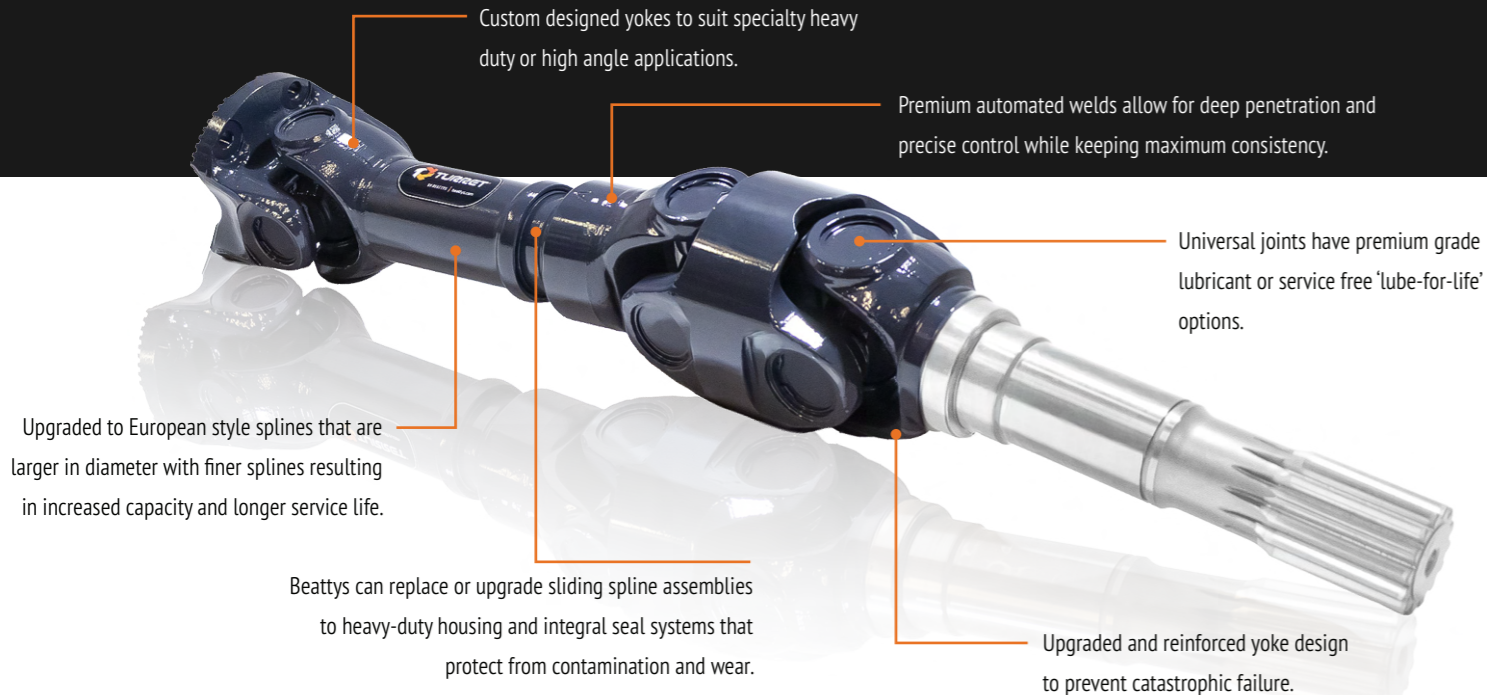

Drive Shafts

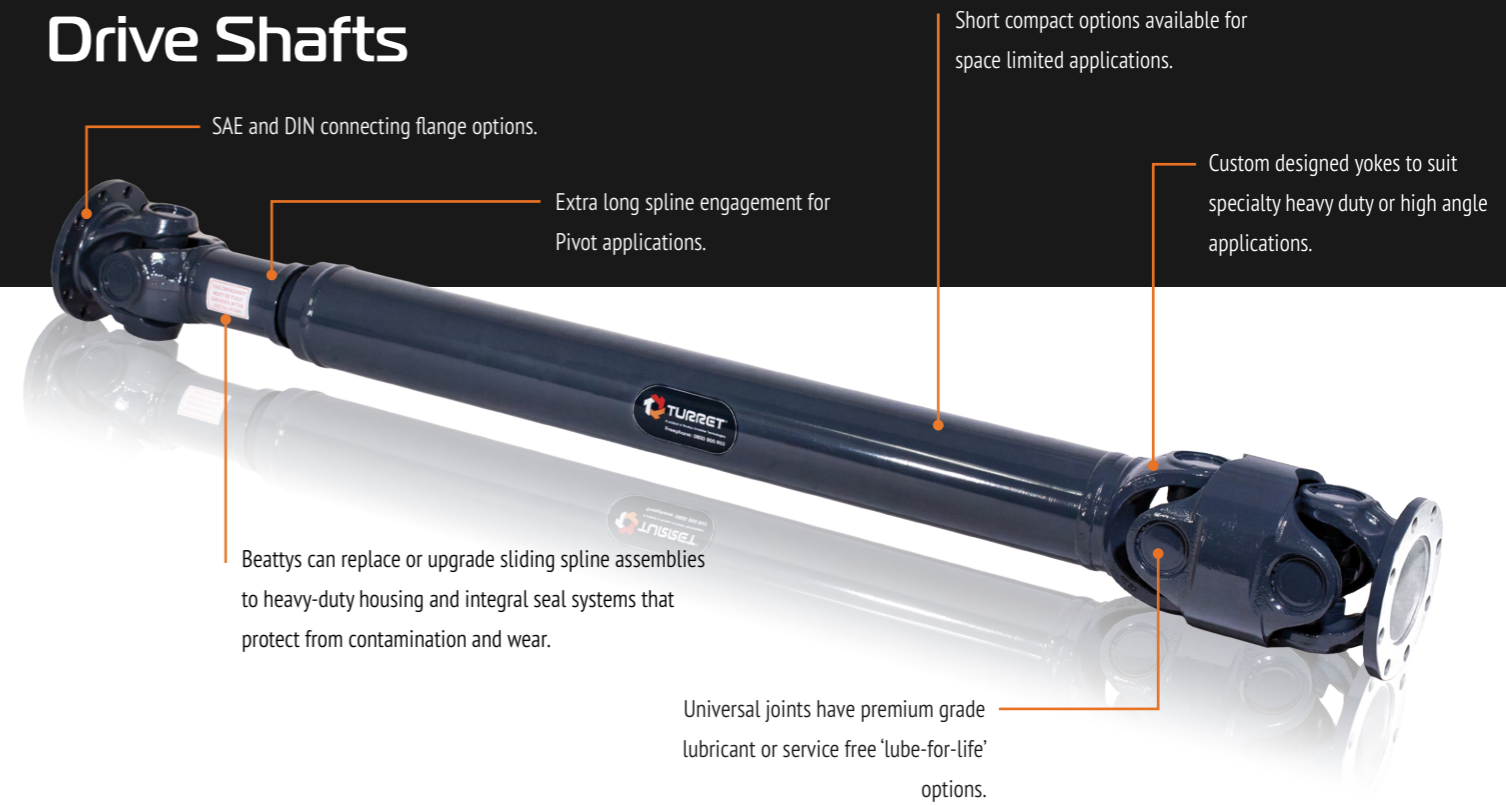

Axle Shafts (Standard)

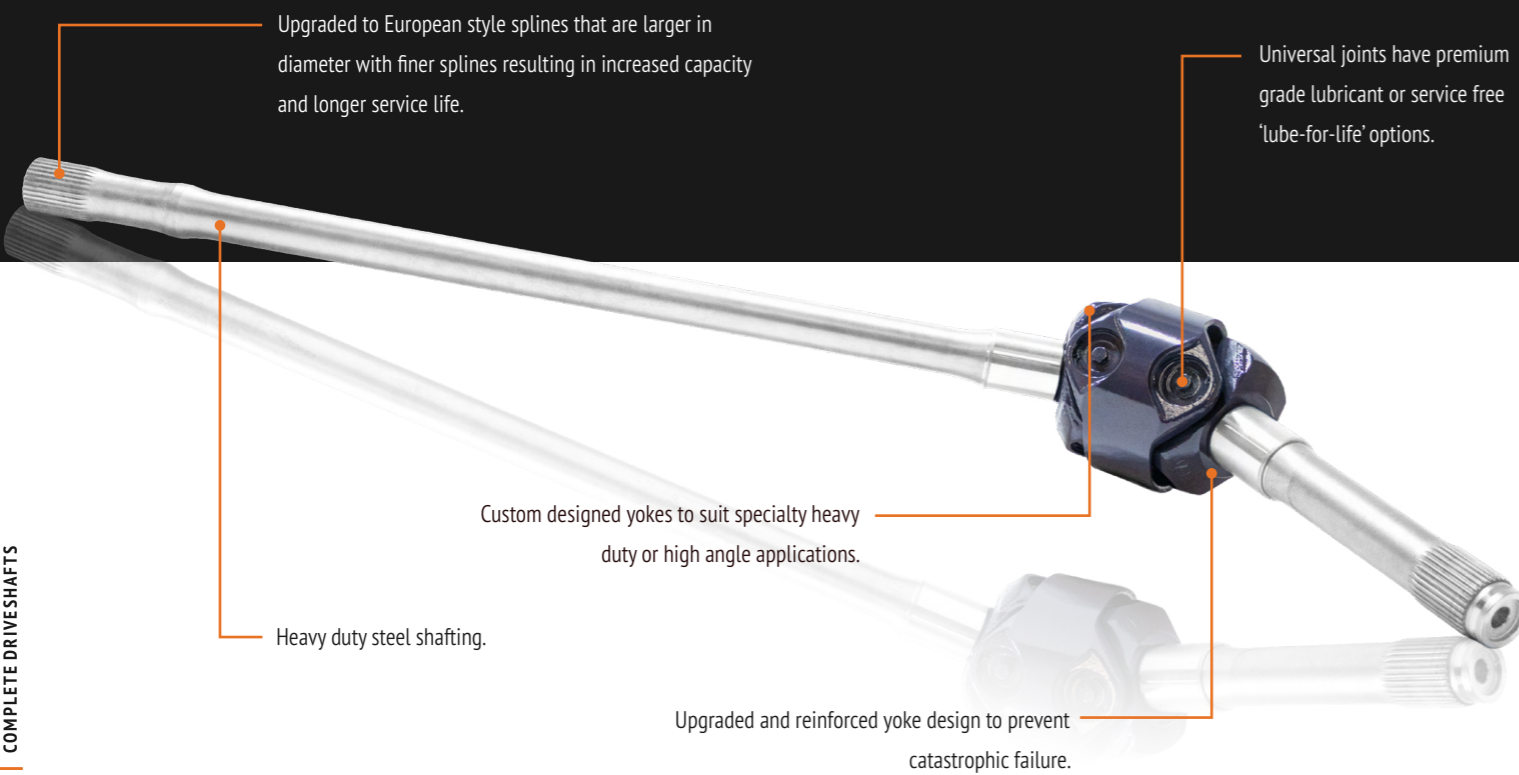

Groundcare Shafts



Marine Driveshafts

Powering the marine industry with optimal performance.

KEY STRENGTHS & BENEFITS:

The marine environment and demands of this industry provide the ultimate challenge for product quality and durability along with the need for proven design expertise. Beattys has risen to this challenge and for many years has enjoyed working alongside Australasia's leading naval architects; assisting them with marine driveline design and is now the preferred supplier for renowned boat builders throughout the region.

Beattys Driveline has made significant investment into specialised equipment and also technical know-how training to ensure our team is at the forefront of the marine industry's requirements, delivering excellence and premium driveline solutions.

All componentry, processes and workmanship are of the highest industry standards and trusted globally by mariners operating both commercial and pleasure vessels.

Premium driveshaft solutions.

European involute-style splines that are larger in diameter with finer tolerances and less clearance result in quieter operation, increased capacity and longer service life.

Rilsan® coated splines reduce axial load and provide electrical isolation between shaft ends.

Sliding spline assemblies have heavy duty housings and an integral seal system that protects from contamination and wear.

Marine grade 2 pack industrial coating preventing corrosion in harsher environments.

Automated welding process allowing deeper penetration and precise control while maintaining maximum consistency.

Internal thrust washers allowing the universal joints to run cooler and minimise noise and vibrations from clearance.



High grade tubing with internal tube damper increasing the resistance to high shock loadings.

All driveshafts are balanced to ISO 1940 Grade 6.3 standard and balance weights are spot-welded to prevent fracturing and stress on the driveshaft tube.

Option of completely sealed universal joints to keep maintenance to a minimum and ensuring engine room cleanliness. Greaseable options also available for higher angle applications.

Custom made flanges to suit any gearbox, engine or prop shaft and remove need for additional adapter flanges.

CV Shafts



OVERVIEW

Turret CV joints and shafts make it possible to have unequal angles on the two ends. This, coupled with a maintenance-free and a low axial force ball design results in long lasting, high performing solutions.

SPECIFICATIONS

- Short coupled options for minimal length requirements as well as tube options to allow for increased operating lengths
- Low axial force ball design resulting in longer lasting high speed operation
- Complete range available from 180 - 3500Nm

Short Coupled Shafts

Sealed or greasable universal joint options.

Heavy duty designed options with upgraded universal joints and centre yokes for competition boats.



Splined end yoke to suit water jet input spline.

Stocked models for common water jet propulsion systems.

Custom designed and manufactured flanges to suit any engine, gearbox or coupling.

Sliding coated involute spline assemblies have heavy-duty housings and an integral seal system that protects from contamination and wear.



Custom designed yokes to suit speciality high torque and angle applications.

Balanced to ISO 1940 standard with balance weights spot-welded to prevent fracturing and stress on the driveshaft tube.

Completely sealed universal joints to keep maintenance to a minimum and ensure the engine room is kept clean.

Adapter Flanges

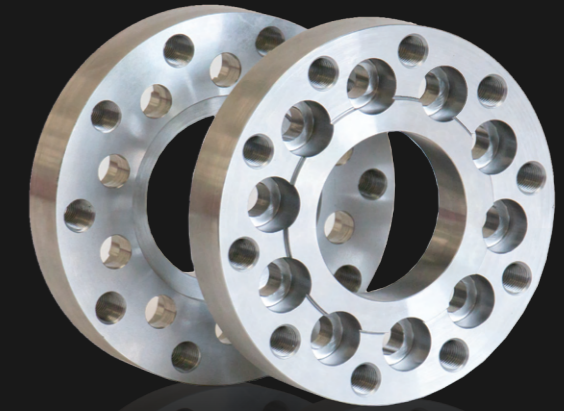

OVERVIEW

Custom made adapter flanges to suit any gearbox, engine or coupling. With the use of advanced 3D CAD software and state-of-the-art machining technologies, we can guarantee the highest degree of accuracy.

SPECIFICATIONS

- Available in both mild steel and aluminium material options
- Full range of custom made adapter flanges to suit all gearbox and engine makes/models



Thrust Bearings

Uniquely designed and manufactured by Beattys' in-house team.

KEY STRENGTHS & BENEFITS:

In all marine applications with conventional shaft drives, the thrust along with vibration from the propeller is transmitted axially through the shaft to the coupling, through the transmission, and on to the engine.

Turret thrust bearings designed and manufactured by Beattys provide the perfect solution in absorbing the thrust and vibrations, while also simplifying engine installation and shaft alignment.

Range:

- Thrust capacity from 3 kN to 60 kN
- Standard flange designs to suit split couplings
- Internal taperloc designs to suit up to 4.0" shaft diameter

Specifications:

- Reduces drivetrain noise by up to 50% compared to any direct drive coupling
- All thrust force is absorbed through rubber pads parallel to the propeller shaft
- Allows for softer engine mounts which further reduces vibrations and noise
- Removes prop thrust off the gearbox increasing service intervals and overall lifetime
- Prevents high frequency vibrations from causing wear and damage to the prop shaft drivetrain
- Saves time and reduces costs with less requirements on propeller shaft alignment

Two, four or six bolt models available depending on thrust requirements.

Current models available up to 2000Hp and 60kN of thrust.

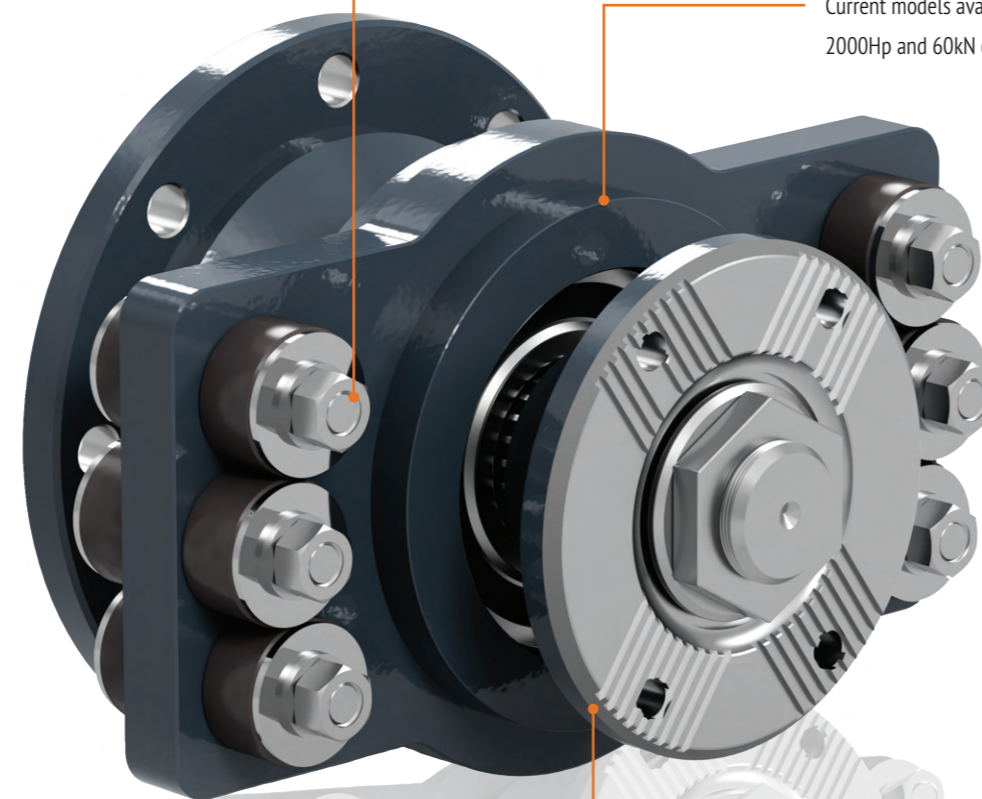

Standard and custom flange bolt patterns available for flexible shaft connections.

Custom designed flanges to connect to any propeller shaft with half coupling machined to suit.

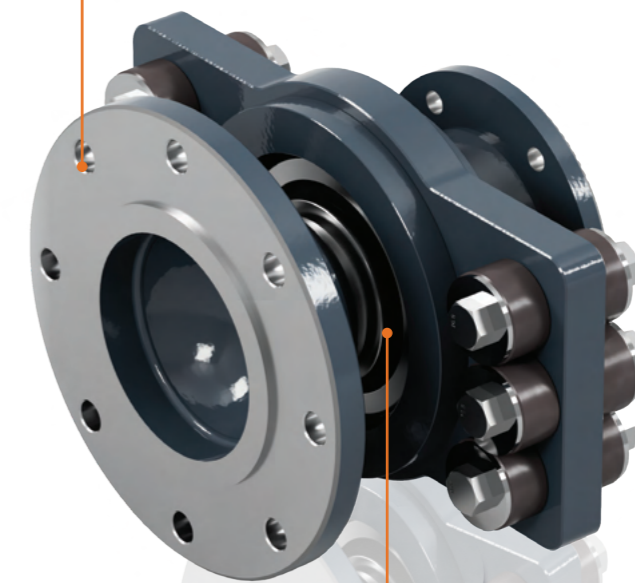

Sealed bearings providing a clean and maintenance-free solution.



Can be used with driveshaft or CV shaft.

Internal clamp system reducing the need for machining the propeller shaft.

Easy to access greasable bearing for fast and easy servicing.

“FOR US - IN ONE WORD - BEATTYS IS RELIABILITY. WE CAN TRUST THE PRODUCT. AS A 24/7 OPERATION, WE CAN'T AFFORD ANYTHING LESS.”

STEVE DANIELS
OJI FIBRE SOLUTIONS PULP MILL

Componentry

UNIVERSAL JOINTS	40
CENTRE BEARINGS	42
MIDSHIP STUBS	43
COMPANION FLANGES	43
END YOKES	44
TRANSMISSION YOKES	44
FLANGE YOKES	45
TUBE YOKES	45
SLIP SETS	46
SLIP YOKES	47
SLIP STUBS	47
YOKE SHAFTS	48
COMPLETE ENDS	48
DOUBLE CARDAN ASSEMBLIES	49
DOUBLE CARDAN PARTS	49
DRIVESHAFT TUBE	50
SMALL PARTS	50
CV JOINTS	51
RUBBER COUPLINGS	51
PRECISION COUPLINGS	52
TORSIONAL COUPLINGS	53

Universal Joints



OVERVIEW

The universal joint is one of the most critical parts in any driveshaft, that's why at Beattys we only use the best. Beattys' Turret universal joints are of the highest industry standards and are trusted by many large organisations nationwide to deliver reliable performance day after day. We are proud to offer the largest stocked range of universal joints in New Zealand covering all applications with over 500 different styles and sizes.

SPECIFICATIONS

- Standard and premium styles
- Triple-lipped seals and interal thrust washers
- Sealed and lubed options
- Offset joints for high angles and axle applications

Universal Joints (Heavy Transport)

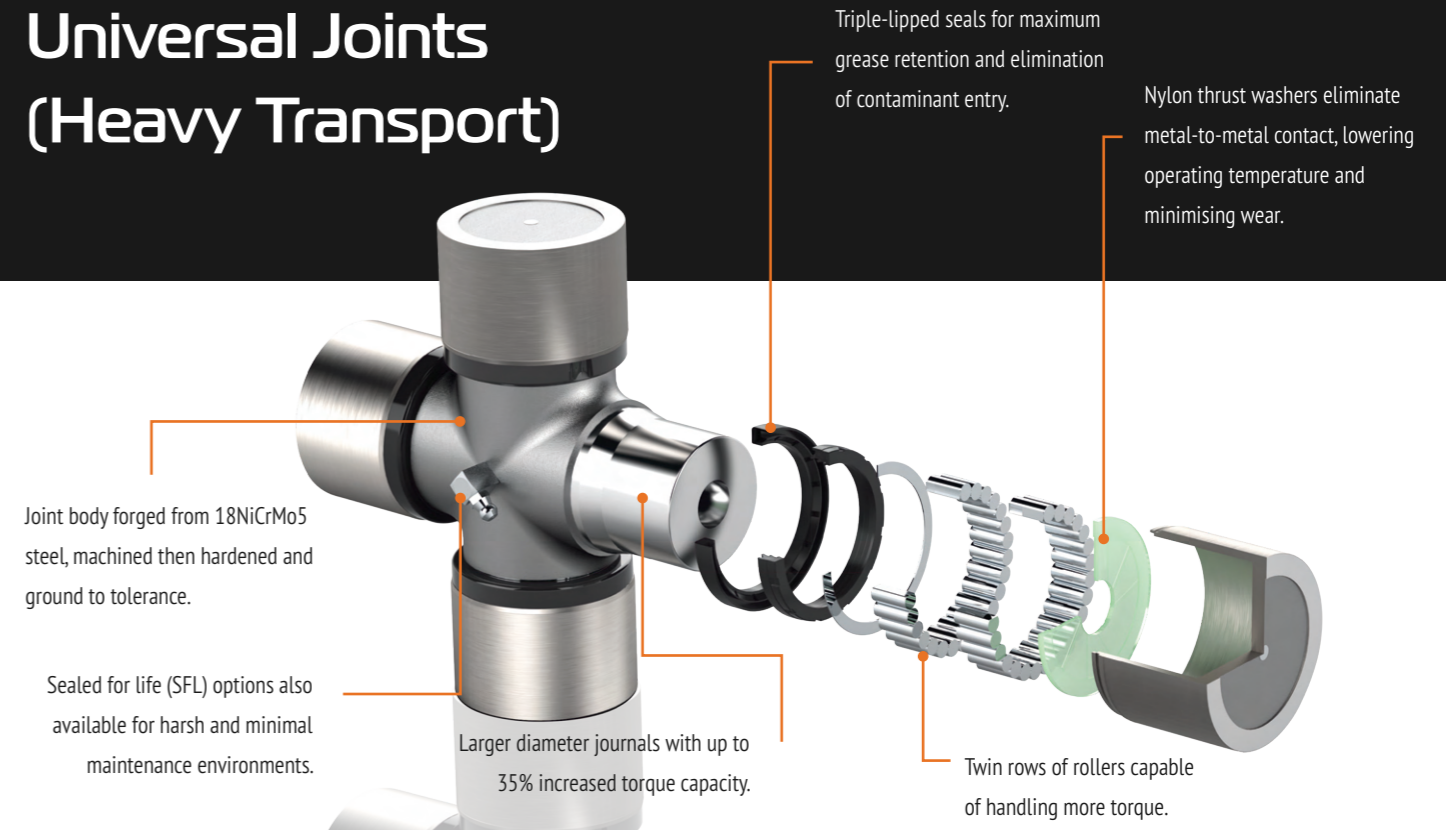

Universal Joints (Off Highway)

Manufactured with premium materials and processes to ensure durability and superior performance.

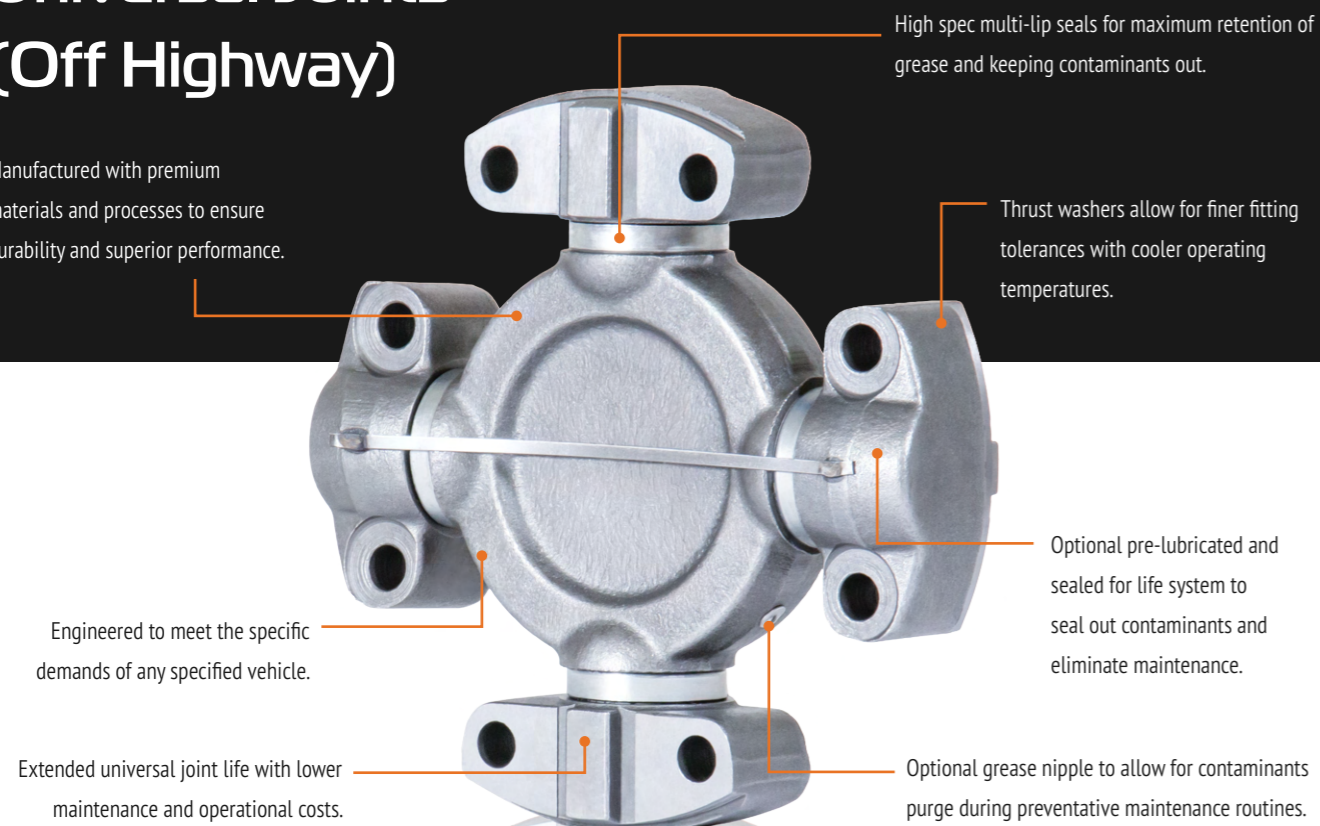

Universal Joints (Industrial)

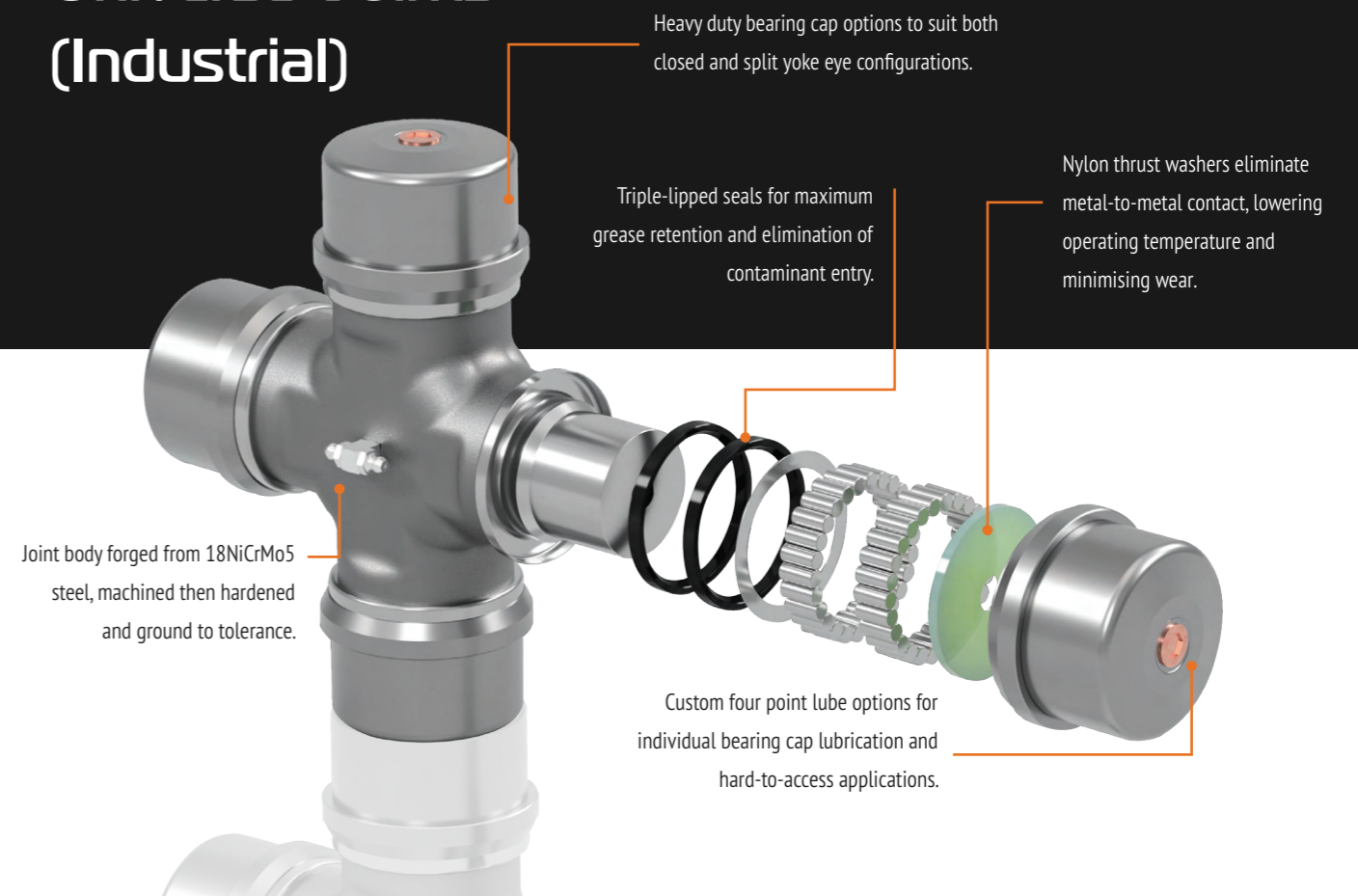

Centre Bearings



OVERVIEW

Beattys' Turret centre bearings always provide optimal alignment, which translates into improved performance and durability of the driveline. Our advanced technology reduces noise and vibration, while maintaining the proper driveline angle to maximise driveshaft and component life. We offer a large range of solutions for all applications including maintenance free options and high-performance marine styles.

SPECIFICATIONS

- Solid and slotted rubber types
- Self-aligning bearings
- Heavy duty options
- Replacement rubber types

Midship Stubs



OVERVIEW

Midship stubs that aren't running within tolerance will cause driveline vibrations and premature wear. Every Turret midship stub is quality checked following final machining to ensure required tolerances are maintained.

SPECIFICATIONS

- From 25 - 70mm bearing diameters
- Standard and reverse style splines
- Rilsen™ coated option on sliding spline midship applications.

Centre Bearings (Heavy Transport)



Companion Flanges

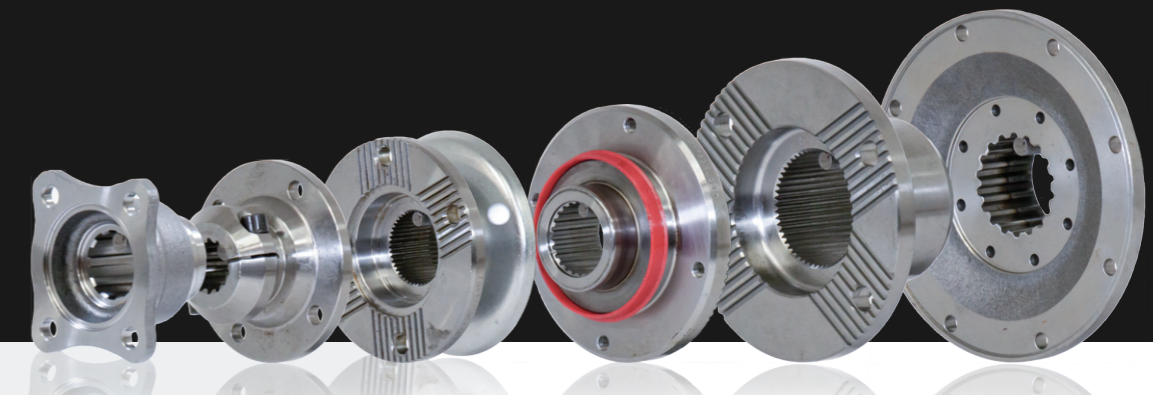

OVERVIEW

Beattys stock a versatile range of Turret companion flanges that are developed from premium quality materials in various sizes and styles. Long lasting in nature and superior in finish, our companion flanges are well suited for a wide range of applications in the automotive, heavy transport, earth moving, industrial and marine industries. We can also customise blank flanges or design and manufacture complete custom solutions as per your requirements.

SPECIFICATIONS

- DIN, SAE and KV series
- Plain bore / keyway
- Square and involute internal splines
- Semi-finished types
- Clamplock types

End Yokes



OVERVIEW

Our end yokes come in a variety of styles and sizes to suit the automotive, heavy transport, earthmoving, industrial and marine industries. Whether you want it with a splined bore or a custom cut keyway we will have one to meet your requirements. What we don't have on our shelves we can custom make in our modern production centre.

SPECIFICATIONS

- Full and half round units
- To suit centre bearings, differential and transmissions
- Clamp type for PTO use

Flange Yokes



OVERVIEW

The multitude of mounting options is forever increasing in the driveshaft industry. That's why Beattys Driveline carries a vast range of different profiles and sizes with many bolt patterns and locating options. Our production centre can also modify a range of blank un-drilled flanges from scratch to meet any custom requirements.

SPECIFICATIONS

- SAE and DIN spec
- KV European
- Single and double joint styles
- Blank type for custom made options

Transmission Yokes



OVERVIEW

Turret transmission yokes are forged, not cast, for greater strength and undergo a precision machining process to guarantee exceptional balance and minimal runout. All our componentry is sourced from market leading suppliers that have the skilled engineers and craftsmen ensuring every yoke is made to exacting standards. We hold a large range of transmission yokes in stock to suit various applications.

SPECIFICATIONS

- Standard and long snouts available
- Various types for American and Japanese vehicles
- Billet steel types for high performance
- Internal/external circlip types

Tube Yokes



OVERVIEW

Tube yokes come in a large range of styles and profiles. All Beattys Turret tube yokes have been sought from the industry leading suppliers around the world. We know how important it is to keep you moving, so we only use the best componentry that has been tested and proved throughout New Zealand over our many years of industry experience.

SPECIFICATIONS

- Solid and hollow type
- To suit various tube diameters in each series
- Standard and high angle

Slip Sets



OVERVIEW

One of the key components for any driveline is the sliding splines. Any wear on these will result in vibrations and premature wear of other moving components. Beattys holds a complete range of Turret slip sets that suit all applications from automotive to industrial. All splines are thoroughly inspected by one of our engineers before leaving our parts department to ensure we continue to provide a high standard of componentry.

SPECIFICATIONS

- Involute splines – European design
- SAE spline for standard series
- Various spline lengths in each series
- Low noise especially for marine applications

Slip Yokes



OVERVIEW

Our extensive range of Turret slip yokes are manufactured to go above and beyond what is expected. We use market leading suppliers that have skilled engineers and craftsmen ensuring every yoke is made to exacting standards. We can offer multiple options for all applications, with premium options like involute European style splines for longer lasting and higher performing driveshafts.

SPECIFICATIONS

- DIN and SAE style splines available
- Dust shields with standard and splined seals
- Various lengths available

Slip Stubs



OVERVIEW

For every slip yoke we supply, we have a slip stub to suit. As with all our other componentry, Turret slip stubs are designed and engineered to outperform and outlast alternative options. We only use the best spline forms that are designed to ensure correct fitment and run out when mated with our slip yokes. With diameters from 25 to 115mm, our range offers a solution to all applications.

SPECIFICATIONS

- Hardened steel and Rilsen™ coated types
- Multiple stub diameters to suit tube options
- Long and short coupled slip types

Yoke Shafts



OVERVIEW

Yoke shafts are mainly used in space limited applications such as interaxle shafts between the two diffs and auxiliary drives. To accommodate all manner of industry applications Turret yoke shafts can be supplied in various lengths, series and styles. We can also custom make certain options to your exact requirements.

SPECIFICATIONS

- Extra short options
- Hardened steel and Rilsen™ cated spline options
- Wide angle yoke options

Double Cardan Assemblies



OVERVIEW

Where driveshafts are operating at high angles there is often a demand for double cardan joints. A pin or ball system in the middle gives the assembly support and allows the driveshaft to operate without premature wear of the universal joints. Mostly these units are used in off-road situations. While we repair and supply double cardan units we also offer design expertise for all high angle driveline configurations.

SPECIFICATIONS

- Complete assemblies
- Individual components
- Heavy duty types
- To suit automotive and off highway applications
- The ultimate solution for unequal angle situations

Complete Ends



OVERVIEW

Our complete ends are available in a range of sizes and styles. Whether it be a tube yoke or a sliding spline option we will have it. All Turret componentry is sourced from top international suppliers guaranteeing high performance in all applications. Coupled with our legendary customer support and parts backup, solutions like these will live up to whatever tough environment they need to.

SPECIFICATIONS

- SAE and DIN spec
- KV European
- Standard and high angle options

Double Cardan Parts



OVERVIEW

At Beattys we stock a complete range of common parts for double cardan joints. These include yokes, ball and spring kits and centre yokes. Keep your driveline running vibration free by upgrading any worn componentry that could cause further damage to other areas of the driveline.

SPECIFICATIONS

- Complete assemblies
- Individual components
- Heavy duty types
- To suit automotive and off highway applications
- Used in unequal angle situations
- Greaseable and sealed options
- Self-centering ball kits
- Wide range of connecting yokes and flang

Driveshaft Tubes

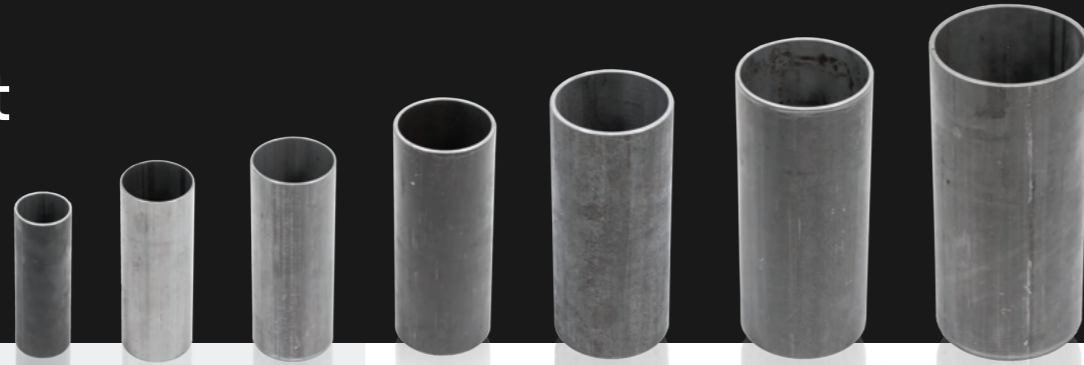

OVERVIEW

At Beattys we stock a complete range of driveshaft tube range from 25mm to over 219mm, with different wall thickness options throughout the complete range. All our tubing is sourced from industry leading suppliers and meets all ISO and other industry standards.

SPECIFICATIONS

- DOM specification
- Supplied in 6m lengths or cut to custom lengths
- Heavy duty industrial tube available
- Alloy tube supplied to order

CV Joints

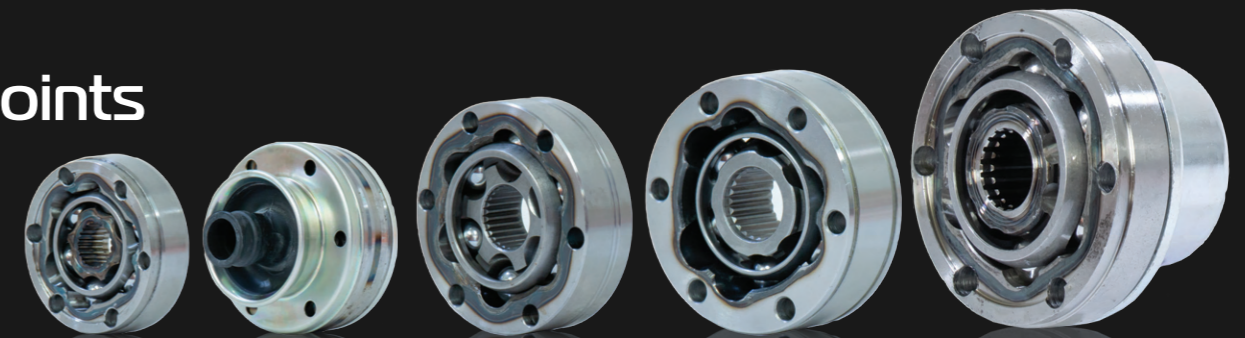

OVERVIEW

Our full suite of constant velocity (CV) joints caters for the automotive, light commercial, industrial and marine industries. All Turret CV joints are sourced from industry leading suppliers and are guaranteed to outperform and out last.

SPECIFICATIONS

- High speed and performance types
- Ideal for difficult angle applications
- Complete range of high speed boots available
- Complete shafts available

Small Parts



OVERVIEW

We hold a complete range of small parts to complement all our driveshaft services and componentry. These include universal joint clamps and plates, bolt kits, spline seals, midship nuts, U-bolts, mounting kits, dust caps, split pins, washers, circlips, balance weights, lock tabs and more.

SPECIFICATIONS

- We can source unusual items
- High quality components
- To suit all makes and models

Rubber Couplings

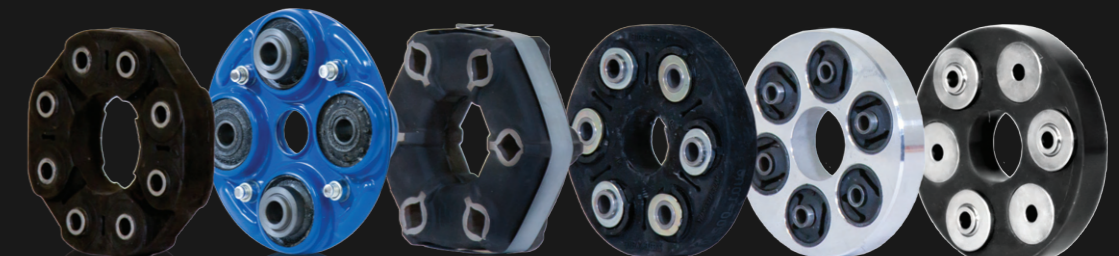

OVERVIEW

Beattys Driveline has a complete range of Turret rubber couplings to suit automotive, transport, industrial and marine applications. With over 55 years of experience in the driveline industry, we know what to look for when it comes to finding premium couplings that last. All rubber couplings we supply are backed by our exceptional service and promise to deliver componentry that provides optimal performance, whatever the challenge.

SPECIFICATIONS

- Quick and easy installation
- Dampens drivetrain disturbances
- Prevents angular misalignment
- Ideal for cars, SUV's and small trucks

Precision Couplings

Over 150 different styles and sizes available.

Double joint options for high angle situations up to 50°.

Models rated from 3.5Nm to 720Nm.

Solid or pre-machined options available.

Tight tolerances reduce wear, noise and results in a longer service life.

Compact design compared to traditional driveshaft alternatives.

Available with precision sliding splines for applications with variable lengths.

Rubber boot kits available for protection from abrasive materials.



- Hardened bush and needle bearings**
Depending on the operating Rpm and transmitted torque loads we have options available from all applications; from steering to high speed industrial applications.
- Double universal joint**
Applications with excessive angle misalignment require double joints to allow for smooth operating. Also available on needle bearing and hardened bush options.
- Stainless steel**
Extend the life of your driveline in corrosive and food grade applications by opting for our full stainless steel option precision coupling.

Torsional Couplings

Absorb engine and gearbox vibrations.

Extremely robust and fail-safe design with rubber rollers subjected only to compressive stress.

Custom options as short as 12mm available for situations where there is very limited space.

Ability to add a heavy duty outer support bearing to remove all thrust off the driveshaft and other components.

Highly flexible coupling with progressive characteristic.

Compatible with all standard flywheel connections and custom flanges can be designed and manufactured according to specifications.

Smooth operation and reliable transmission over the entire power range with minimal energy loss.

Slight stiffness at lower speeds and a moderately increased stiffness at rising torques.

Industrial Balancing

ON SITE BALANCING	56
IMPELLERS & ARMATURES	56
FANS & PROPELLERS	57
SCROLLS, ROLLERS & DRUMS	58
FLAIL ROTORS & CHIPPING DRUMS	58
OTHER ROTATIONAL EQUIPMENT	59

“I HAVE WORKED WITH BEATTYS FOR 20 PLUS YEARS FOR ALL OUR BALANCING REQUIREMENTS. I WILL CONTINUED USING BEATTYS WELL INTO THE FUTURE.”

STUART MCEWEN
NEW ZEALAND STEEL LIMITED



On Site Balancing

OVERVIEW

Equipped with an innovative mobile devices, technicians are able to visit your site nationwide to diagnose and remedy vibration problems 'on the spot', eliminating the need for costly dismantling and freighting of machinery. Difficult access or remote locations no longer present an obstacle to having your componentry dynamically balanced.

APPLICATIONS

- Air conditioning units
- Cooling tower fans
- Field equipment / machinery
- Air handling units
- Bandsaw wheels



Fans & Propellers

OVERVIEW

Beattys has a long association with the ventilation, air conditioning and marine industries having balanced hundreds of fans. The need for displacement of air and propulsion in the water opens up a large market for rotating items with either fins or fan blades that will benefit from improved efficiency and reduced maintenance costs when dynamically balanced. Our team is used to working with specialist materials including stainless steel, fibreglass and plastic.

APPLICATIONS

- HVAC industry
- Propellers
- Centrifugal fans
- Fibreglass fans
- Dust extraction
- Air handling units
- Axial fans
- Turbines
- Fan Blades



Impellers & Armatures

OVERVIEW

Beattys has a long history of supporting plant reliability through precision dynamic balancing of repaired impellers and armatures during pump rebuilds. Improving balance grades to meet client requirements and ensuring couplings run smoothly are all part of reducing vibration and minimising downtime. Our technicians understand the urgency of getting equipment back online and bring practical experience to a wide range of rotors

APPLICATIONS

- Pump impellers
- Fan impellers
- Electric motors
- Pump shafts
- Multi-stage pump impellers
- Armatures
- Couplings



Scrolls, Rollers & Drums

OVERVIEW

Beattys has assisted manufacturing plants across New Zealand for many years with the dynamic balancing of industrial rotating equipment. With machines capable of handling components over 4 meters in length, 10 tonnes in weight, and up to 4.5 meters in diameter, we've balanced a wide variety of items. By working closely with our clients, we provide a service that keeps production flowing.

APPLICATIONS

- Rollers
- Centrifuges
- Sanding rollers
- Rubber rollers
- Vacuum screws
- Sifters
- Scrolls / Augers
- Turbochargers
- Separators
- Compressor screws
- Food processing drums



Other Rotational Equipment

OVERVIEW

Rotating equipment regardless of its weight, size and application, will have a related industry standard balancing grade to maximise efficiency and protect against premature wear and failure. We also have a wide range of balancing mandrels to suit various applications or can custom manufacture to suit.

APPLICATIONS

- Pulleys
- Crankshafts
- Cutter heads
- Bandsaw wheels
- Gears
- Compressor screws
- High speed machine tool components



Flail Rotors & Chipping Drums

OVERVIEW

We have the expertise and experience to remove vibration issues from rotors across a broad range of applications. From tree chippers through to high speed agricultural drums, our specialised equipment is capable of balancing all shapes and sizes including rotating components up to 4.5 meters in diameter and 10 tonne in weight.

APPLICATIONS

- Flail drums
- Chipper drums
- Mutching drums
- Blades / Chipper discs
- Stump grinding rotors



DRIVELINE SOLUTIONS TO DRIVE YOUR BUSINESS FURTHER

When it comes to drivelines, at Beattys we get satisfaction from resolving any challenge that comes through our world-class workshop. This not only comes from our can do attitude, but is backed by technical expertise, leading-edge manufacturing robotics and advanced design facilities. No matter the project - from a single specialist vehicle to a national fleet - there isn't a driveline problem we can't solve.

0800 800 852 / enquiries@beattys.com / beattys.co.nz

100% FAMILY OWNED
FAMILY PROUD